

# 8435 SE 47th: Drainage Report

Steinborn Residence

Owner:

Daniel and Susan Steinborn  
8435 SE 47<sup>th</sup> Place  
Mercer Island, WA 98040

Prepared by:

WR Consulting, Inc.  
3611 45<sup>th</sup> Ave W.  
Seattle, WA 98199  
Contact: John W. Rundall, P.E.

February 17, 2022  
Project No. 21016



# TABLE OF CONTENTS

	<u>Page</u>
1.0 EXECUTIVE SUMMARY .....	1
1.1 Project Drainage Description.....	1
1.2 Flow Control.....	1
1.3 Water Quality Measures .....	1
2.0 PROJECT OVERVIEW .....	2
2.1 Project Drainage Description.....	2
2.2 Existing Soils.....	3
2.3 Critical Areas.....	4
2.4 Existing Drainage .....	4
3.0 DRAINAGE IMPROVEMENTS .....	6
3.1 Conveyance .....	6
3.2 Flow Control and Detention Volume .....	6
3.3 Outfall Piping .....	8
3.4 Easement for Development to the North .....	8
4.0 STORMWATER POLLUTION PREVENTION PLAN.....	9
4.1 Purpose of Plan.....	9
4.2 Water Quality Monitoring .....	9
4.3 Permanent Stabilization.....	9
5.0 MAINTENANCE AND OPERATION.....	10
5.1 Maintenance.....	10
5.2 Operation.....	10
Appendix A: Vicinity Map, Legal Description, Parcel Number and Drainage Areas .....	11
Appendix B: Permit Plans.....	12
Appendix C Stormwater Pollution Prevention Plan (SWPPP).....	13
Appendix D Operation and Maintenance .....	14

## LIST OF FIGURES

	Page
Figure 1 – Project Location – Aerial Image.....	2
Figure 2 – Soils Map.....	3
Figure 3 – Critical Area Review .....	4
Figure 4 – City of Mercer Island Drainage Infrastructure .....	5

## 1.0 EXECUTIVE SUMMARY

### 1.1 Project Drainage Description

The project consists of the development of a single family residence including a driveway up a steep slope to access the new construction. Several site walls including soil nailing stabilization will be installed to allow for the construction of the new building and associated driveway and parking court.

The site will be graded around the perimeter of the house and along the driveway to construct the improvements and stabilize the slopes where they meet the new structures. The remainder of the site will be undisturbed and existing trees and vegetation will be preserved.

As a result, stormwater runoff collection will be limited to the following constructed impervious surfaces: the roof, entry access paving, vehicle parking/auto court and the driveway. Conveyance piping will be constructed down the driveway and will discharge to the City of Mercer Island drainage facilities on the north side of SE 47<sup>th</sup> Place. This conveyance piping is sized to accommodate drainage from a development north (uphill) of the parcel to allow their runoff to drain by gravity rather than a pumped system.

This shared conveyance will require an easement through the Steinborn property which is expected to be on the order of ten feet wide. Terms of the easement and an agreement for the shared use and maintenance of the pipe are currently being negotiated.

### 1.2 Flow Control

In accordance with City of Mercer Island requirement, flow control is required for the project and the facility is sized in accordance with the requirements outlined in the City of Mercer Island Development Services Group On-site Detention Design Requirements. The size of the facility and corresponding flow control elements were established from Table 1 of that document based on the Type of soils on the property. Attachment 1 showing the construction details of the facility is included in the Permit drawing set in Appendix B.

Due to the site constraints, primarily limited space from steep slopes, the detention system is provided by two separate tanks. The total volume of the tank is based on the area of new impervious and the factors outlined in Table 1. This volume was apportioned based on the proportion of runoff tributary area of each facility. The upper facility serves the house and upper driveway and is positioned under the auto court/turn around in front of the garage. The lower facility is at the bottom of the driveway and provides flow control for the driveway.

The flow control orifice sizes and heights were selected from Table for the length and diameter of each storage volume for Type C soils.

### 1.3 Water Quality Measures

Water Quality Treatment is not required for the project, however, a catch basins with a down-turned outlets are provided prior to discharge into the City system. The flow control facilities (detention tanks) also provide 6" of sediment storage to address Water Quality.

Any disturbed areas will be stabilized with mulch and restoration to prevent sediment transport or other erosion of soils. The remaining undisturbed portion of the property does not require any further stabilization to prevent erosion of sediments.

## 2.0 PROJECT OVERVIEW

### 2.1 Project Drainage Description

The proposed improvements consist of the construction of a house on the property at 8435 SE 47<sup>th</sup> Place. See aerial photo (Figure 1) below:



Figure 1 - Project Location – Aerial Image

Project Address:

8435 SE 47<sup>th</sup> Place  
Mercer Island, WA 98040

Lot Area: 19,360 SF

The project vicinity map and additional information about the lot including the legal description and the Parcel Number are in Appendix A.

## Area of New Impervious Surfacing

The following table summarizes the area of the new impervious surfacing for the project. These drainage areas are shown on the Area Summary which is included in Appendix A.

<b>Total Site Area:</b>		19,361	sf
<b>Existing Impervious Area:</b>			
		-	sf
<b>Total Existing Impervious:</b>		-	sf
<b>Proposed Impervious Area:</b>			
<b>Storage No. 1</b>			
Roof		3,178	sf
Entry Driveway		988	sf
Entry Walkway/ADU Access		208	sf
<b>Subtotal New Impervious:</b>		4,374	sf
<b>Storage No. 2</b>			
Entry Driveway (below 264 contour)		1,394	sf
<b>Subtotal New Impervious:</b>		1,394	sf
<b>Total New Impervious:</b>		5,768	sf

## 2.2 Existing Soils

The site drains south to a roadside ditch on the north side of SE 47<sup>th</sup> Place. Based on the USGS Soils map, the site is predominantly underlain by Kitsap silt loam (KpD) soils (see map below) which is a Type D soil. The Type C classification has been used for sizing the proposed detention facility because the Type D soils on-site are less permeable.

Map Unit Legend			
King County Area, Washington (WA633)			
King County Area, Washington (WA633)			
Map Unit Symbol	Map Unit Name	Acres in AOI	Percent of AOI
AgC	Alderwood gravelly sandy loam, 8 to 15 percent slopes	1.4	8.0%
AmC	Arents, Alderwood material, 6 to 15 percent slopes	8.7	48.3%
KpB	Kitsap silt loam, 2 to 8 percent slopes	3.8	21.4%
KpD	Kitsap silt loam, 15 to 30 percent slopes	4.0	22.3%
<b>Totals for Area of Interest</b>		<b>18.0</b>	<b>100.0%</b>



Figure 2 – Soils Map

## 2.3 Critical Areas

Much of the site is identified as a steep slope critical area and a Critical Area Review (CAR-2) is required. Figure 3 (below) is a screen shot of the Critical Areas Plan and shows the steep slopes on the property. The Critical Area Plan addresses the steep slope requirements for the project.

The main impact of the steep slope on the stormwater facilities are the construction details of the detention facility. Since these tanks will be in the vicinity of steep slopes, all joints must meet the requirement of being watertight rather than the typical requirement of “soil tight” for this type of installation. The watertight construction will not allow leakage that could saturate surrounding soils and reduce the stability of the slopes. In addition, the soil nailing stabilization and walls constructed for the project will address slope stability requirements as needed in this area.



Figure 3 – Critical Area Review

## 2.4 Existing Drainage

The following map from the MI GIS records shows the existing City of Mercer Island drainage facilities in the area. The site identified as 84XX and is currently undeveloped. It is forested and drains by sheet flow toward the south. A roadside ditch on the north side of SE 47<sup>th</sup> Place collects runoff and conveys it eastward. A City owned storm drain system of culvert and catch basins conveying runoff from properties to the west also discharge into the ditch. The development of the driveway access to this project will require modifications to the storm drain system in the right of way and extension of culverts allow traffic to cross over the existing ditch.

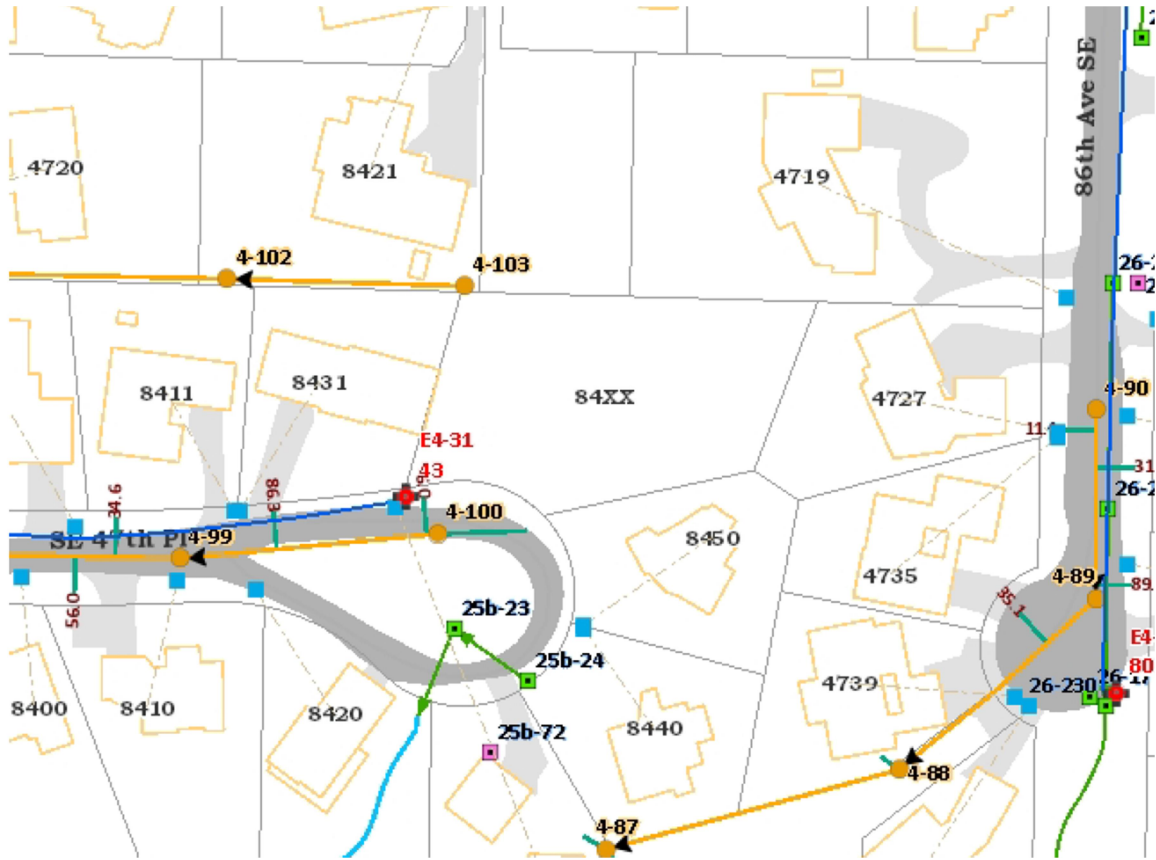

Figure 4 – City of Mercer Island Drainage Infrastructure



### 3.0 DRAINAGE IMPROVEMENTS

#### 3.1 Conveyance

A limited number of conveyance pipes are required to collect stormwater from downspouts or area drains and convey the runoff to the Detention structure before discharging to the City of Mercer Island system. On-site conveyance piping is a minimum of 4” in diameter and will be installed at a minimum slope of 2%. The impervious surface runoff will be routed through the detention pipe and foundation drainage will be conveyed to the conveyance piping that carries the detention tank discharge to the City system. The main conveyance pipe through the site (down the driveway) has been up-sized to 8” diameter to also convey runoff from the development to the north (see Section 3.4). (See Permit Plans, Appendix B).

#### 3.2 Flow Control and Detention Volume

The detention volume is based on the City of Mercer Island Development Services Group On-site Detention Design requirements as outlined the Detention Requirements updated January 26, 2018. In accordance with the requirements, On-site Detention is required as follows:

to be infeasible for roofs and/or other hard surfaces.

**Is On-site Detention Required For My Project?**

**YES**, if my project:

- 1) Results in 2,000 square feet, or greater, of new plus replaced hard surface area, or
- 2) Has a land disturbing activity or 7,000 square feet or greater, or
- 3) Results in a **net increase** of impervious surface of 500 square feet or greater.

**AND**

- 1) All of the on-site stormwater BMPs included on List #1 and List #2 are determined to be infeasible for roofs and/or other hard surfaces, and
- 2) Drainage from the site will be discharged to a storm and surface water system that includes a watercourse or there is a capacity constraint in the system.

The project results in more than 2,000 sf of new and replaced impervious and due to the steep slopes, on-site storm water BMPs in Lists #1 and #2 are not feasible. The site also drains to a water course so On-site Detention is required for the project. The On-site Detention was sized using Table 1 in the Requirements Handout as shown below. Type C soils were selected as noted in Section 2.2, above with the detention tank size circled in red.

**Table 1**  
ON-SITE DETENTION DESIGN FOR PROJECTS BETWEEN 500 SF AND 9,500 SF NEW PLUS REPLACED IMPERVIOUS SURFACE AREA

New and Replaced Impervious Surface Area (sf)	Detention Pipe Diameter (in)	Detention Pipe Length (ft)		Lowest Orifice Diameter (in) <sup>(3)</sup>		Distance from Outlet Invert to Second Orifice (ft)		Second Orifice Diameter (in)	
		B soils	C soils	B soils	C soils	B soils	C soils	B soils	C soils
500 to 1,000 sf	36"	30	22	0.5	0.5	2.2	2.0	0.5	0.8
	48"	18	11	0.5	0.5	3.3	3.2	0.9	0.8
	60"	11	7	0.5	0.5	4.2	3.4	0.5	0.6
1,001 to 2,000 sf	36"	66	43	0.5	0.5	2.2	2.3	0.9	1.4
	48"	34	23	0.5	0.5	3.2	3.3	0.9	1.2
	60"	22	14	0.5	0.5	4.3	3.6	0.9	0.9
2,001 to 3,000 sf	36"	90	66	0.5	0.5	2.2	2.4	0.9	1.9
	48"	48	36	0.5	0.5	3.1	2.8	0.9	1.5
	60"	30	20	0.5	0.5	4.2	3.7	0.9	1.1
3,001 to 4,000 sf	36"	120	78	0.5	0.5	2.4	2.2	1.4	1.6
	48"	62	42	0.5	0.5	2.8	2.9	0.8	1.3
	60"	42	26	0.5	0.5	3.8	3.9	0.9	1.3
4,001 to 5,000 sf	36"	134	91	0.5	0.5	2.8	2.2	1.7	1.5
	48"	73	49	0.5	0.5	3.6	2.9	1.6	1.5
	60"	46	31	0.5	0.5	4.6	3.5	1.6	1.3
5,001 to 6,000 sf	36"	162	109	0.5	0.5	2.7	2.2	1.8	1.6
	48"	90	59	0.5	0.5	3.5	2.9	1.7	1.5
	60"	54	37	0.5	0.5	4.6	3.6	1.6	1.4
6,001 to 7,000 sf	36"	192	128	0.5	0.5	2.7	2.2	1.9	1.8
	48"	102	68	0.5	0.5	3.7	2.9	1.9	1.6
	60"	64	43	0.5	0.5	4.6	3.6	1.8	1.5
	36"	216	146	0.5	0.5	2.8	2.2	2.0	1.9

As noted in the Executive Summary, the storage is divided into two parts because there is insufficient room for a single large tank at the bottom of the driveway. So part of the storage (Storage No. 1) is located under the auto court in front of the garage. This volume provides flow control for the roof, pedestrian walks and the upper driveway. Storage No. 2 is located at the bottom of the driveway to provide flow control for the driveway, prior to discharge to the City system on SE 47<sup>th</sup> Place. (See Permit Plans, Appendix B)

The orifices for the two tanks were selected from Table 1 based on the sizes of the tank at the two locations. The following table shows the elevations of the orifices and riser based on the Table 1 criteria. The plans in Appendix A include Attachment 1 (City of Mercer Island detention tank template) which includes the elevation and orifice data for both tanks. The drawing has also been edited to include additional pipe requirement for a “watertight” material due to the location relative to the slope below.

**Table 1**

ON-SITE DETENTION DESIGN FOR PROJECTS BETWEEN 500 SF AND 9,500 SF NEW PLUS REPLACED IMPERVIOUS SURFACE AREA

New and Replaced Impervious Surface Area (sf)	Detention Pipe Diameter (in)	Detention Pipe Length (ft)		Lowest Orifice Diameter (in) <sup>(3)</sup>		Distance from Outlet Invert to Second Orifice (ft)		Second Orifice Diameter (in)	
		B soils	C soils	B soils	C soils	B soils	C soils	B soils	C soils
500 to 1,000 sf	36"	30	22	0.5	0.5	2.2	2.0	0.5	0.8
	48"	18	11	0.5	0.5	3.3	3.2	0.9	0.8
	60"	11	7	0.5	0.5	4.2	3.4	0.5	0.6
1,001 to 2,000 sf	36"	66	43	0.5	0.5	2.2	2.3	0.9	1.4
	48"	34	23	0.5	0.5	3.2	3.3	0.9	1.2
	60"	22	14	0.5	0.5	4.3	3.6	0.9	0.9
2,001 to 3,000 sf	36"	90	66	0.5	0.5	2.2	2.4	0.9	1.9
	48"	48	36	0.5	0.5	3.1	2.8	0.9	1.5
	60"	30	20	0.5	0.5	4.2	3.7	0.9	1.1
3,001 to 4,000 sf	36"	120	78	0.5	0.5	2.4	2.2	1.4	1.6
	48"	62	42	0.5	0.5	2.8	2.9	0.8	1.3
	60"	42	26	0.5	0.5	3.8	3.9	0.9	1.3
4,001 to 5,000 sf	36"	134	91	0.5	0.5	2.8	2.2	1.7	1.5
	48"	73	49	0.5	0.5	3.6	2.9	1.6	1.5

<b>Orifice Size and Height/Elevation:</b>			
<b>Storage No. 1 - 28 LF of 60" Diameter Pipe, IE 257.0</b>			
	<u>Diameter</u>	<u>Distance above Outlet (ft)</u>	<u>Elevation of Orifice</u>
Second Orifice:	1.3 inches	3.9	261.40
Lowest Orifice	0.50 inches	0.0	257.50
Top of Riser	6 inches		262.00
<b>Storage No. 2 - 9 LF of 60" Diameter Pipe, IE 244.0</b>			
	<u>Diameter</u>	<u>Distance above Outlet (ft)</u>	<u>Elevation of Orifice</u>
Second Orifice:	0.60 inches	3.4	247.90
Lowest Orifice	0.50 inches	0.0	244.50
Top of Riser	6 inches		249.00

### 3.3 Outfall Piping

The proposed Detention Tank outfall has been over-sized to accommodate flows from the development to the north. The 8” storm drain follows the west edge of the driveway and connects to the City of Mercer Island system in the right of way. The City of Mercer Island system has been improved to provide a catch basin at the connection point and extends the existing culvert outlet to the east to allow the construction of the driveway access for the property.

### 3.4 Easement for Development to the North

As noted in Section 3.3 above, the storm drain piping through the Steinborn property has been sized in anticipation of conveying stormwater from the 3 lot development immediately to the north of the site. The Steinborns and the developers of that north lot are currently negotiating terms for the shared facility including apportioning costs for the construction and outlining requirements for maintenance. The Steinborns believe the installation of a gravity outlet for that development to the north is an important aspect of stormwater management in the area because the north developments reliance on a pumping facility above the steep slope creates added risk to the Steinborn site. The construction of a shared gravity conveyance pipe reduces that risk and provides a lower cost and more sustainable approach (less energy required) for storm water management for both sites.

## **4.0 Stormwater Pollution Prevention Plan**

### **4.1 Purpose of Plan**

The Construction Sediment Control (CSC) measures shown on the plans are the temporary BMPs selected for stormwater runoff quality treatment during construction of this project. A BMP is a physical, structural, and/or managerial practice that prevents or reduces the pollution of water. The goal of the CSC measures are to prevent pollution from leaving the site and to meet Water Quality Standards as defined in WAC 173-201A. Should field conditions during construction require additional BMPs or if a change in placement of BMPs is needed, this plan shall be modified in order to meet objectives of the CSC. Those objectives are:

- To implement BMPs to minimize erosion and sedimentation from rainfall at construction sites, and to identify, reduce, eliminate, or prevent the pollution of stormwater.
- To prevent violations of surface water quality, ground water quality, or sediment management standards.
- To prevent, during the construction phase, adverse water quality impacts including impacts on beneficial uses of the receiving water downstream of the outfall.

During active work, the Contractor shall keep on site, at all times, the construction documents showing the CSC measures. All work will be in accordance with the requirements of the City of Mercer Island. A copy of the Stormwater Pollution Prevention Plan (SWPPP) is included in Appendix C.

### **4.2 Water Quality Monitoring**

The Contractor will monitor water quality in accordance with the SWPPP. If needed, the Contractor will measure turbidity, pH and temperature at site discharge points after each 24-hour rainfall events of 0.5 inches or greater. If turbidity at any of the site discharge points exceeds the water quality standards (WAC 173-201A), then the Contractor shall make appropriate adjustments to the CSC plan. Turbidity will be measured with a HACH 2100P portable turbidity meter or equivalent and reported in Nephelometric Turbidity Units (NTUs). The following standards will be applied:

1. Turbidity shall not exceed 5 NTU over background turbidity when the background turbidity is 50 NTU or less, or have more than a 10 percent increase in turbidity when the background turbidity is more than 50 NTU. If turbidity exceeds these requirements, a formal Water Quality Monitoring Plan should be implemented
2. Visually monitor for turbid water or off-site sedimentation. Check for potential BMP improvements if sediment is accumulating off-site, or if the discharge appears turbid. The Contractor shall be responsible for confirming that no turbid water or sediment leaves the site.

### **4.3 Permanent Stabilization**

The permanent stabilization BMPs for this project consist of: 1) paving surfaces with stable materials or covering with roof structures to prevent erosion, 2) amending soil and re-establishing vegetation in disturbed areas, and 3) ongoing maintenance of storm water facilities. All drainage facilities will be maintained in good working condition and kept clean of sediment by the owners.

## **5.0 Maintenance and Operation**

### **5.1 Maintenance**

Maintenance requirements are limited for the proposed gravity system for this project. Regular monitoring of structures and piping is needed to ensure that the system is functioning properly. Maintenance is required to keep inlets and grates free of debris or other obstructions. If grates are kept clear and catch basins regularly maintained, the risk of fouling pipes is significantly reduced.

Details about maintenance of catch basins and the detention pipe and flow control structure are included in Appendix D.

### **5.2 Operation**

There are no operational requirements to the system because it is designed to convey or store runoff using only gravity; there are no pumps in the system. Regular maintenance as outlined in Section 5.1 is required to ensure that the facility continues to operate as designed.

# Appendix A

## Vicinity Map, Legal Description and Parcel Number Drainage Areas

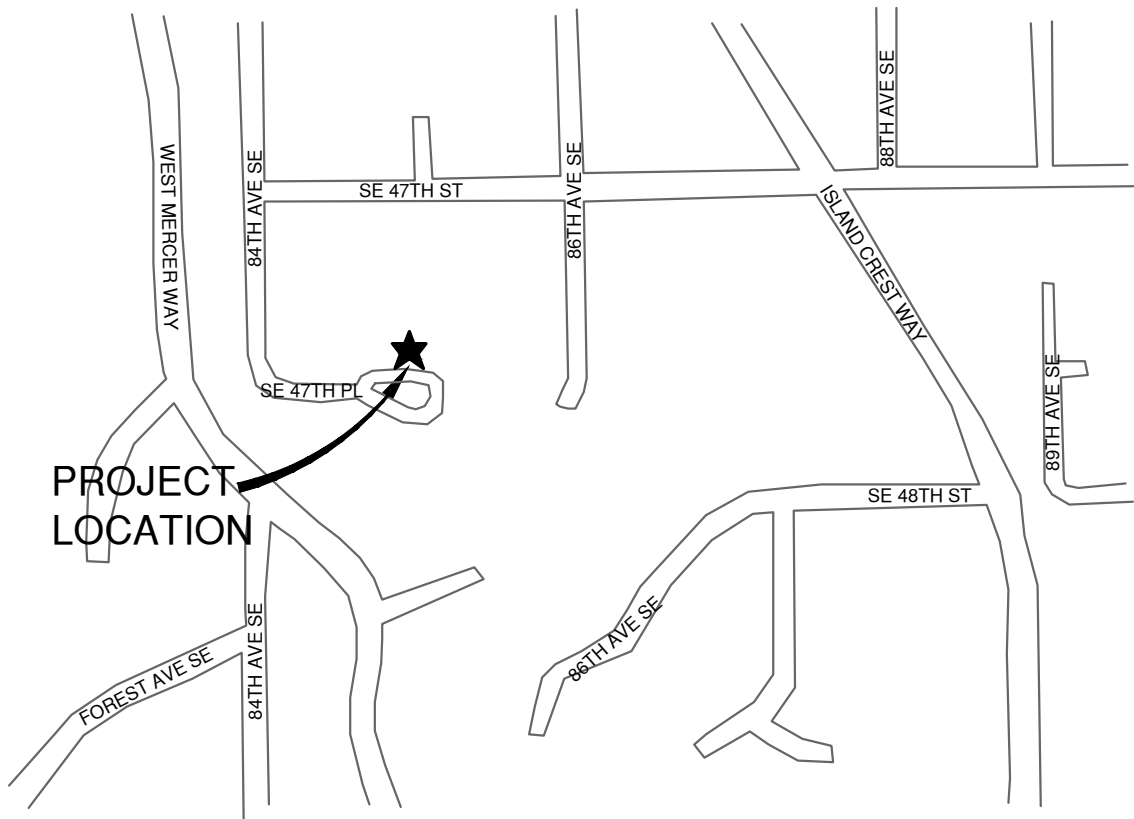

PROJECT  
LOCATION

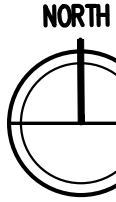

VICINITY MAP

8435 SE 47th Place

SCALE: 1" = 400'

LEGAL DESCRIPTION:

LOT 4, HILL HIGH ESTATES AS RECORDED  
IN VOLUME 68 OF PLATS, PAGE 28,  
RECORDS OF KING COUNTY, WASHINGTON.

SITUATE IN THE COUNTY OF KING, STATE  
OF WASHINGTON.

PARCEL NUMBER:

331750-0040

LOT AREA:

19,361 SF

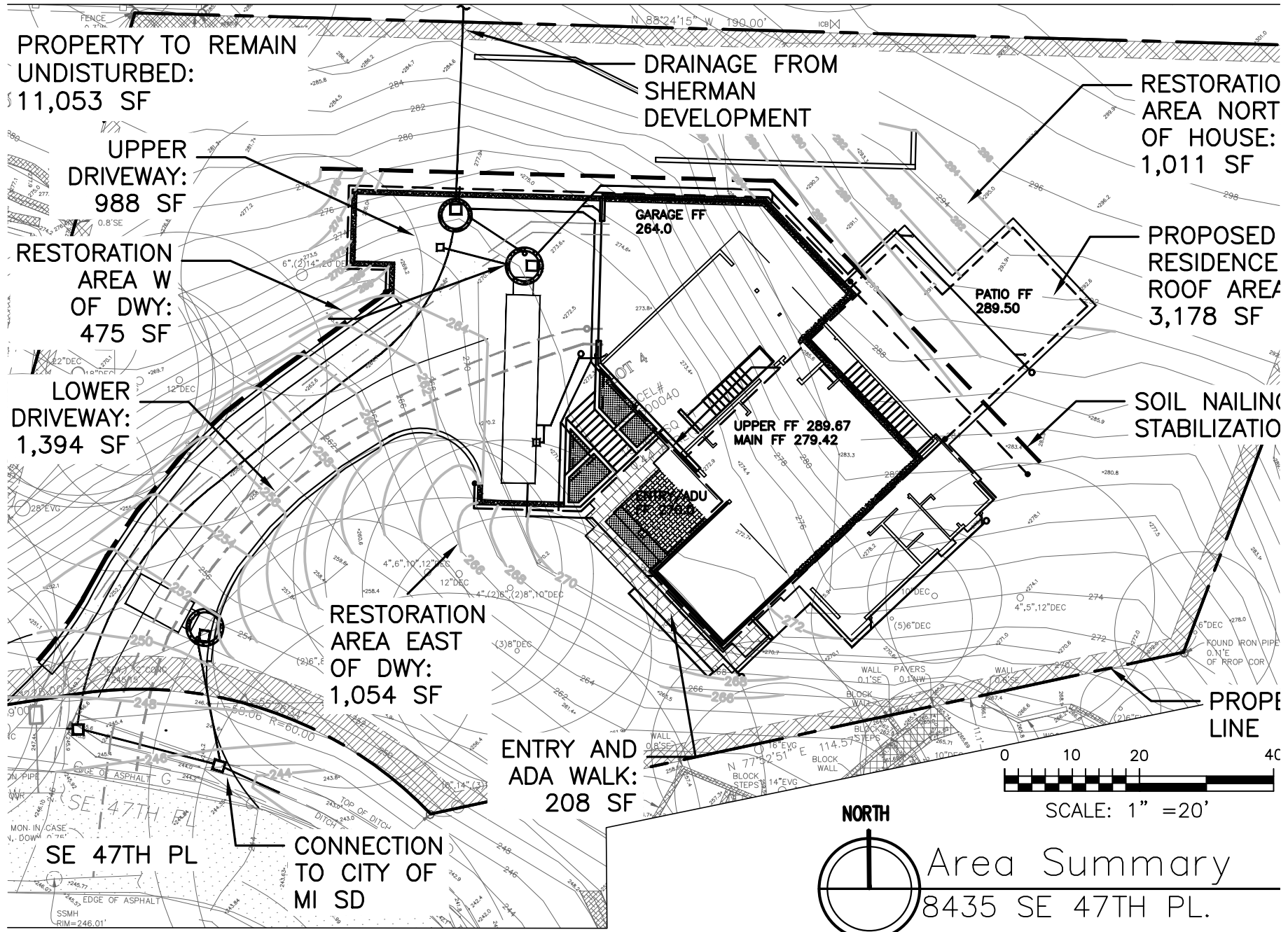

PROPERTY TO REMAIN UNDISTURBED:  
11,053 SF

UPPER DRIVEWAY:  
988 SF

RESTORATION AREA W OF DWY:  
475 SF

LOWER DRIVEWAY:  
1,394 SF

RESTORATION AREA EAST OF DWY:  
1,054 SF

ENTRY AND ADA WALK:  
208 SF

CONNECTION TO CITY OF MI SD

DRAINAGE FROM SHERMAN DEVELOPMENT

RESTORATION AREA NORTH OF HOUSE:  
1,011 SF

PROPOSED RESIDENCE ROOF AREA:  
3,178 SF

SOIL NAILING STABILIZATION

PROPE LINE

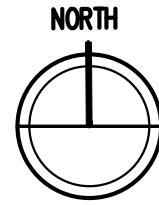
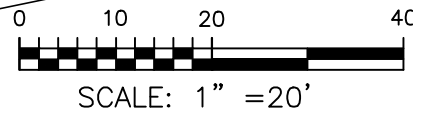

Area Summary  
8435 SE 47TH PL.



# Appendix B

## Permit Drawings

**GENERAL NOTES**

- ALL WORK AND MATERIALS SHALL BE IN ACCORDANCE WITH THE LATEST EDITION OF THE CITY OF MERCER ISLAND STANDARD SPECIFICATIONS, AND WSDOT/APWA STANDARD SPECIFICATIONS, LATEST EDITION. THE CITY OF MERCER ISLAND RESERVES THE RIGHT TO REJECT ANY DAMAGED AND/OR NON-COMPLIANT CONSTRUCTION MATERIAL.
- PRIOR TO ANY CONSTRUCTION ACTIVITY, THE CONTRACTOR SHALL SCHEDULE AND ATTEND A PRE-CONSTRUCTION CONFERENCE WITH THE CITY OF MERCER ISLAND CONSTRUCTION INSPECTION PERSONNEL.
- AN APPROVED PLAN SET MUST BE ON THE JOB SITE WHENEVER CONSTRUCTION IS IN PROGRESS.
- ALL SITE WORK IMPROVEMENTS SHALL BE CONSTRUCTED TO OBTAIN STREET USE AND ANY OTHER RELATED PERMITS PRIOR TO ANY CONSTRUCTION ACTIVITY.
- IT SHALL BE THE SOLE RESPONSIBILITY OF THE CONTRACTOR TO OBTAIN STREET USE AND ANY OTHER RELATED PERMITS PRIOR TO ANY CONSTRUCTION ACTIVITY.
- ANY APPROVED CUTS OF EXISTING PUBLIC ROADWAYS SHALL BE BACK FILLED AND COMPACTED IN ACCORDANCE WITH CITY OF MERCER ISLAND STANDARDS. ALL CUTS INTO EXISTING ASPHALT SHALL BE ALONG NEAT, CONTINUOUS, SAWED, OR WHEEL CUT LINES. A TEMPORARY COLD MIX PATCH MUST BE PLACED IMMEDIATELY AFTER BACKFILL AND COMPACTION. THIS EXISTING ROAD CUT SHALL BE REPLACED WITH AT LEAST THREE (3) INCHES OF COMPACTED CL "B" ASPHALT CONCRETE, SIX (6) INCH CRUSHED ROCK SURFACING TOP COURSE (5/8 INCH MINUS), AS REQUIRED DEPENDENT UPON A SOILS ENGINEER'S RECOMMENDATION AND TESTS. IN NO CASE SHALL THE REPLACEMENT BE LESS THAN THE EXISTING SECTION.
- PAVED SURFACES INCLUDING ROADWAYS, SIDEWALKS, AND CURBS THAT ARE DAMAGED BY NEW CONSTRUCTION SHALL BE REPAIRED AS REQUIRED BY THE CITY OF MERCER ISLAND INSPECTOR.
- ALL LOCATIONS OF EXISTING UTILITIES SHOWN HEREON HAVE BEEN ESTABLISHED BY FIELD SURVEY OR OBTAINED FROM AVAILABLE RECORDS AND SHOULD THEREFORE BE CONSIDERED APPROXIMATE ONLY AND NOT NECESSARILY COMPLETE. IT IS THE SOLE RESPONSIBILITY OF THE CONTRACTOR TO INDEPENDENTLY VERIFY THE ACCURACY OF ALL UTILITY LOCATIONS SHOWN AND TO FURTHER DISCOVER AND AVOID ANY OTHER UTILITIES NOT SHOWN HEREON WHICH MAY BE AFFECTED BY THE IMPLEMENTATION OF THIS PLAN.
- THE CONTRACTOR SHALL LOCATE AND PROTECT ALL CASTINGS AND UTILITIES DURING CONSTRUCTION AND SHALL CONTACT THE UNDERGROUND UTILITIES LOCATOR SERVICE (1-800-424-5555) AT LEAST 48 HOURS PRIOR TO CONSTRUCTION.
- THE CONTRACTOR SHALL ADJUST ALL EXISTING MANHOLE RIMS, DRAINAGE STRUCTURE LIDS, VALVE BOXES, AND UTILITY ACCESS STRUCTURES TO FINISH GRADE WITHIN AREAS AFFECTED BY THE PROPOSED IMPROVEMENTS.
- UTILITY SERVICE CONNECTIONS SHOWN ON THIS PLAN ARE TO BE MAINTAINED PRIVATELY AND NOT BY THE CITY OF MERCER ISLAND.
- THE CONTRACTOR SHALL PROVIDE AND MAINTAIN TEMPORARY SEDIMENTATION COLLECTION FACILITIES TO ENSURE THAT SEDIMENT-LADEN WATER DOES NOT ENTER THE NATURAL OR PUBLIC DRAINAGE SYSTEM. AS CONSTRUCTION PROGRESSES AND UNEXPECTED (SEASONAL) CONDITIONS DICTATE, MORE SILTATION CONTROL FACILITIES MAY BE REQUIRED TO INSURE COMPLETE SILTATION CONTROL OF THE PROJECT. THEREFORE, DURING THE COURSE OF CONSTRUCTION IT SHALL BE THE OBLIGATION AND RESPONSIBILITY OF THE CONTRACTOR TO ADDRESS ANY NEW CONDITIONS THAT MAY BE CREATED BY HIS ACTIVITIES AND TO PROVIDE ADDITIONAL FACILITIES THAT MAY BE NEEDED TO PROTECT ADJACENT PROPERTIES.
- THE CONTRACTOR SHALL KEEP OFF-SITE STREETS CLEAN AT ALL TIMES BY SWEEPING. WASHING OF THESE STREETS WILL NOT BE ALLOWED WITHOUT PRIOR CITY OF MERCER ISLAND APPROVAL.
- ALL TRAFFIC CONTROL SHALL BE IN ACCORDANCE WITH THE TRAFFIC CONTROL MANUAL.
- CARE SHALL BE EXERCISED WHEN EXCAVATING NEAR EXISTING CHARGED WATER MAINS.

**SURVEY NOTE:**

UNDERGROUND UTILITIES AND EXISTING IMPROVEMENTS SHOWN ARE BASED UPON THE SURVEY "TOPOGRAPHIC AND BOUNDARY SURVEY, STEINBORN PROPERTY, BY TERRANE, DATED FEBRUARY 21, 2021 AND RECORD DRAWINGS. NO WARRANTY OR GUARANTEE OF ACCURACY OR COMPLETENESS IS EITHER IMPLIED OR EXPRESSED. EXISTING UNDERGROUND UTILITIES AND IMPROVEMENTS HAVE BEEN SHOWN ON THIS DRAWING FOR THE PURPOSE OF ASSISTING THE CONTRACTOR IN LOCATING SAID UTILITIES AND IMPROVEMENTS IN THE FIELD. THE CONTRACTOR SHALL BE RESPONSIBLE FOR CHECKING WITH APPROPRIATE AGENCIES THAT MAY HAVE UNDERGROUND UTILITIES AND IMPROVEMENTS WITHIN THE PROJECT LIMITS AND FOR CHECKING LOCATIONS IN THE FIELD. THE CONTRACTOR SHALL BE SOLELY RESPONSIBLE FOR ANY AND ALL DAMAGE TO UNDERGROUND UTILITIES AND IMPROVEMENTS RESULTING FROM HIS OPERATION.

**VERTICAL DATUM**

NAVD88 PER GPS OBSERVATIONS

FIELD DATA FOR THIS SURVEY WAS OBTAINED BY DIRECT FIELD MEASUREMENTS WITH A CALIBRATED ELECTRONIC 5-SECOND TOTAL STATION AND/OR SURVEY GRADE GPS OBSERVATIONS. ALL ANGULAR AND LINEAR RELATIONSHIPS ARE ACCURATE AND MEET THE STANDARDS SET BY WAC 332-130-090.

**GENERAL DRAINAGE NOTES**

- ALL WORK AND MATERIALS SHALL BE IN ACCORDANCE WITH THE LATEST EDITION OF THE CITY OF MERCER ISLAND STANDARD SPECIFICATIONS AND WSDOT/APWA STANDARD SPECIFICATIONS, LATEST EDITION AND THE REQUIREMENTS OF THE DEPARTMENT OF ECOLOGY STORMWATER MANAGEMENT MANUAL FOR WESTERN WASHINGTON.
- PRIOR TO ANY CONSTRUCTION ACTIVITY, THE CONTRACTOR SHALL SCHEDULE AND ATTEND A PRE-CONSTRUCTION CONFERENCE WITH CITY OF MERCER ISLAND CONSTRUCTION INSPECTION PERSONNEL.
- ALL STORM DRAINAGE IMPROVEMENTS SHALL BE CONSTRUCTED IN ACCORDANCE WITH THESE APPROVED PLANS. ANY DEVIATION FROM THESE PLANS WILL REQUIRE APPROVAL FROM THE OWNER, ENGINEER AND APPROPRIATE PUBLIC AGENCIES.
- IT SHALL BE THE SOLE RESPONSIBILITY OF THE CONTRACTOR TO OBTAIN STREET USE AND ANY OTHER RELATED PERMITS PRIOR TO ANY CONSTRUCTION ACTIVITY.
- ALL STORM DRAIN PIPE MAY BE CONSTRUCTED OF ONE OF THE FOLLOWING MATERIALS UNLESS OTHERWISE SPECIFIED IN THE PLANS. ALL PIPE JOINTS MUST BE GASKETED WATER-TIGHT AND MUST BE OF THE SAME MATERIAL AS THE PIPE. ALL PIPE SHALL HAVE A MINIMUM COVER AS SPECIFIED AND SHALL BE ADEQUATELY PROTECTED DURING CONSTRUCTION (REFER TO THE MANUFACTURER'S RECOMMENDATIONS FOR MINIMUM COVER FOR HEAVY EQUIPMENT LOADINGS). THE CITY OF MERCER ISLAND PUBLIC WORKS DEPARTMENT SHALL EXERCISE THE OPTION TO ACCEPT OR REJECT ALL DAMAGED OR NON-COMPLIANT CONSTRUCTION MATERIAL. THE CONTRACTOR/DEVELOPER SHALL BE RESPONSIBLE FOR ALL COSTS ASSOCIATED WITH REJECTED OR SUBSTITUTED CONSTRUCTION MATERIAL.
- PIPE SHALL BE AS FOLLOWS: PVC - FOUR (4) INCH THROUGH EIGHTEEN (18) INCH DIAMETER PIPE, WITH TWENTY FOUR (24) INCH TO THIRTY SIX (36) INCH OF COVER SHALL BE IN ACCORDANCE WITH ASTM D3034 SDR 21. FOUR (4) INCH THROUGH EIGHTEEN (18) INCH DIAMETER PIPE, WITH ASTM D3034 SDR 35 SHALL HAVE THIRTY SIX (36) INCHES MINIMUM COVER. ALL JOINTS SHALL BE PUSH-ON WITH RUBBER GASKETS. PVC STORM PIPE REQUIRES SAND COLLARS MEETING ASTM D-3034-78 SDR 35 SPECIFICATIONS (I.E. CATCH BASIN CONNECTION) OR KOR-N-SEAL BOOTS.
- ALL PIPE BEDDING SHALL BE APWA TYPE "F" FOR FLEXIBLE PIPE (I.E. PVC, SMP OR ADS). BEDDING MATERIAL SHALL BE 5/8 INCH MINUS CRUSHED ROCK ONLY.
- ALL TRENCH BACKFILL IN AREAS OF FUTURE PAVEMENT OR STRUCTURAL LOADING SHALL BE COMPACTED TO AT LEAST 95 PERCENT OF THE MAXIMUM DRY DENSITY PER ASTM D 1557-70 (MODIFIED PROCTOR). ALL OTHER AREAS SHALL BE COMPACTED TO 90 PERCENT MINIMUM).
- CONSTRUCTION OF DEWATERING (GROUNDWATER INTERCEPTION) SYSTEMS SHALL BE IN ACCORDANCE WITH THE APWA STANDARD SPECIFICATIONS, SECTION 61-3.02.
- THE CONTRACTOR SHALL KEEP OFF-SITE STREETS CLEAN AT ALL TIMES BY SWEEPING. WASHING THESE STREETS WILL NOT BE ALLOWED WITHOUT PRIOR CITY OF MERCER ISLAND APPROVAL.
- ALL STORMWATER FACILITIES WILL BE INSTALLED AND IN OPERATION PRIOR TO OR IN CONJUNCTION WITH ALL CONSTRUCTION ACTIVITY UNLESS THAT ACTIVITY EXCEEDS THE CAPACITY AND INTENT OF THE EROSION/SEDIMENTATION CONTROL FACILITY OR UNLESS OTHERWISE APPROVED BY THE CITY.
- RELAY EXISTING SERVICE DRAINS AND SIDE SEWERS TO CLEAR OVER OR UNDER THE NEW UTILITY AS APPROVED BY THE INSPECTOR.

**EROSION CONTROL/CONSTRUCTION SEQUENCE**

- ARRANGE AND ATTEND PRE-CONSTRUCTION MEETING WITH BETWEEN OWNER OR OWNER'S REPRESENTATIVE AND CITY OF MERCER ISLAND SITE INSPECTOR.
- CONTRACTOR'S SURVEYOR TO ESTABLISH AND STAKE OUT CONTROL POINTS FOR WORK.
- INSTALL STRAW WATTLE BARRIERS AND GRATE INLET PROTECTION.
- CONSTRUCT STABILIZED CONSTRUCTION ENTRANCE (IF REQUIRED).
- CLEAR AND GRUB AREA.
- CONSTRUCT OR INSTALL SOIL STABILIZATION MEASURES.
- COORDINATE REMOVAL AND CAPPING OF EXISTING UTILITY LINES WITH APPROPRIATE PURVEYOR.
- GRADE SITE PER PLAN. STABILIZE GRADED AREAS WITH TEMPORARY EROSION CONTROL MEASURES AS REQUIRED.
- CONSTRUCT SITE IMPROVEMENTS.
- HYDROSEED REMAINING DISTURBED AREAS.
- RETURN SILTATION CONTROL AREAS TO ORIGINAL GROUND CONDITIONS.
- REMOVE REMAINING TEMPORARY EROSION/SEDIMENTATION CONTROL ONLY AFTER SITE HAS BEEN STABILIZED AND CITY OF MERCER ISLAND SITE INSPECTOR HAS APPROVED THE REMOVAL.

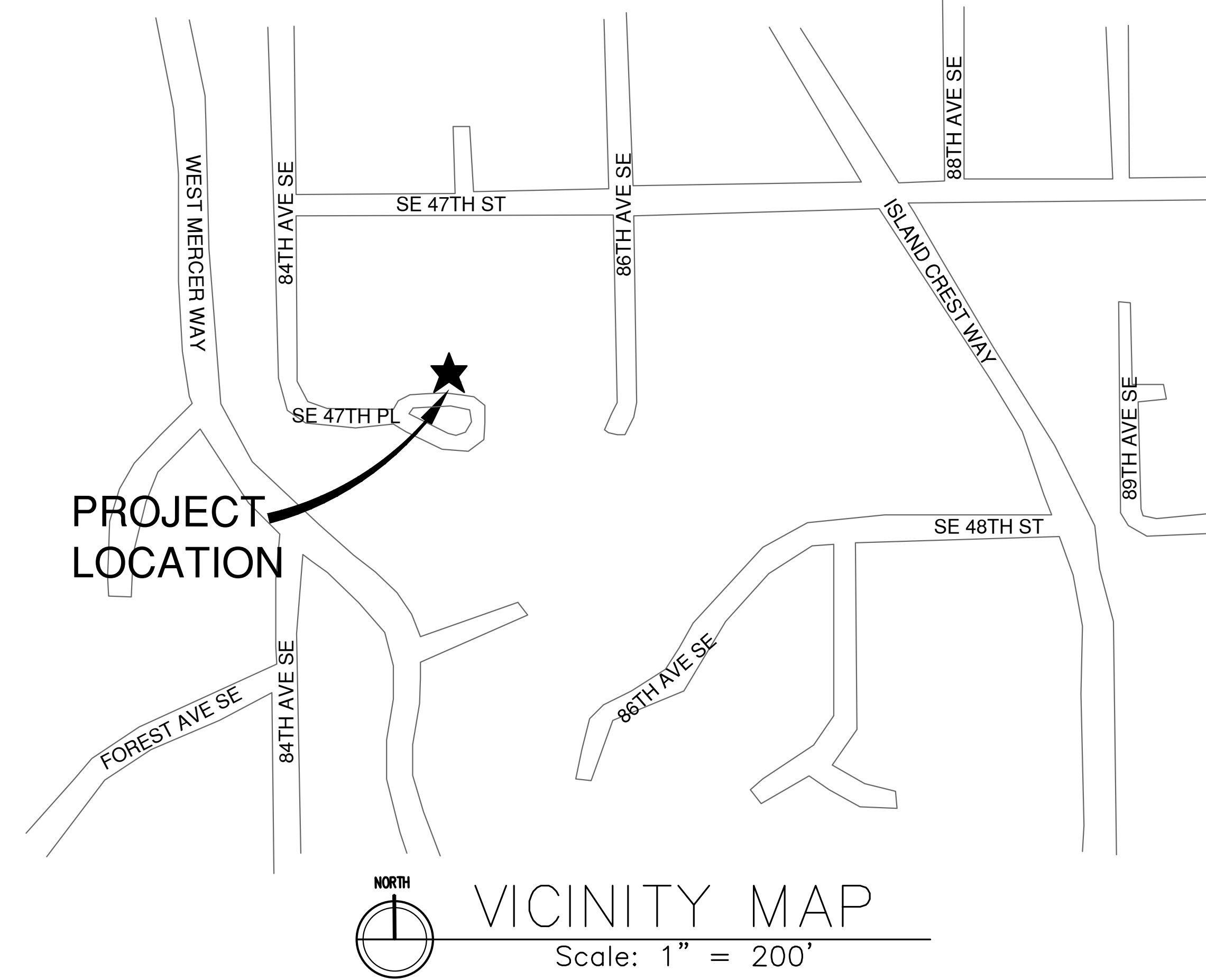

**TEMPORARY EROSION/SEDIMENTATION CONTROL (ESC) NOTES**

- APPROVAL OF THIS TEMPORARY EROSION/SEDIMENTATION CONTROL PLAN (TESC) DOES NOT CONSTITUTE AN APPROVAL OF PERMANENT ROAD OR DRAINAGE DESIGN (E.G. SIZE AND LOCATION OF ROADS, PIPES, RESTRICTORS, CHANNELS, RETENTION FACILITIES, UTILITIES, ETC.)
- THE IMPLEMENTATION OF THESE TESC AND THE CONSTRUCTION, MAINTENANCE, REPLACEMENT AND UPGRADING OF THESE TESC FACILITIES IS THE RESPONSIBILITY OF THE APPLICANT/CONTRACTOR UNTIL ALL CONSTRUCTION IS APPROVED.
- THE TESC FACILITIES SHOWN ON THIS PLAN MUST BE CONSTRUCTED PRIOR TO ALL CLEARING AND GRADING ACTIVITIES, AND IN SUCH A MANNER TO ENSURE THAT SEDIMENT LADEN WATER DOES NOT ENTER THE DRAINAGE SYSTEM OR VIOLATE APPLICABLE WATER STANDARDS.
- THE TESC FACILITIES SHOWN ON THIS PLAN ARE THE MINIMUM REQUIREMENTS FOR ANTICIPATED SITE CONDITIONS. DURING THE CONSTRUCTION PERIOD, THESE TESC FACILITIES SHALL BE UPGRADED (E.G. ADDITIONAL SUMPS, RELOCATION OF DITCHES AND SILT FENCES, ETC.) AS NEEDED FOR UNEXPECTED STORM EVENTS AND AS THE CITY REQUIRES.
- THE TESC FACILITIES SHALL BE INSPECTED DAILY BY THE APPLICANT/CONTRACTOR AND MAINTAINED AS NECESSARY TO ENSURE THEIR CONTINUED FUNCTIONING AND OPERATION.
- ANY AREA STRIPPED OF VEGETATION, INCLUDING ROADWAY EMBANKMENTS, WHERE NO FURTHER WORK IS ANTICIPATED FOR A PERIOD OF TWO (2) DAYS, SHALL BE IMMEDIATELY STABILIZED WITH THE APPROVED TESC METHODS (E.G. SEEDING, MULCHING, NETTING, EROSION BLANKETS, ETC.) GRASS SEEDING ALONE WILL BE ACCEPTABLE ONLY DURING THE MONTHS OF APRIL THROUGH OCTOBER INCLUSIVE.
- ANY AREA NEEDING TESC MEASURE, NOT REQUIRING IMMEDIATE ATTENTION, SHALL BE ADDRESSED WITHIN FIFTEEN (15) DAYS.
- THE TESC FACILITIES ON INACTIVE SITES SHALL BE INSPECTED AND MAINTAINED A MINIMUM OF ONCE A MONTH OR WITHIN 48 HOURS FOLLOWING A STORM EVENT AND AS THE CITY DEEMS NECESSARY.
- AT NO TIME SHALL MORE THAN ONE (1) FOOT OF SEDIMENT BE ALLOWED TO ACCUMULATE WITHIN A CATCH BASIN. ALL CATCH BASINS AND CONVEYANCE LINES SHALL BE CLEANED PRIOR TO PAVING. THE CLEANING OPERATION SHALL NOT FLUSH SEDIMENT LADEN WATER INTO THE DOWNSTREAM SYSTEM.
- STABILIZED CONSTRUCTION ENTRANCES AND WASH PADS PER CITY STANDARDS, SHALL BE INSTALLED AT THE BEGINNING OF CONSTRUCTION AND MAINTAINED FOR THE DURATION OF THE PROJECT. ADDITIONAL MEASURES MAY BE REQUIRED TO ENSURE THAT ALL PAVED AREAS ARE KEPT CLEAN FOR THE DURATION OF THE PROJECT.
- DURING THE TIME PERIOD OF NOVEMBER 1ST THROUGH MARCH 31ST, ALL PROJECT DISTURBED AREAS THAT ARE TO BE LEFT UNWORKED FOR MORE THAN TWO (2) DAYS SHALL BE COVERED BY ONE OF THE FOLLOWING COVER MEASURES: MULCH, SODDING OR PLASTIC COVERING.
- WHERE SEEDING FOR TEMPORARY EROSION CONTROL IS REQUIRED, FAST GERMINATING GRASSES SHALL BE APPLIED AT AN APPROPRIATE (E.G. ANNUAL OR PERENNIAL RYE APPLIED AT APPROXIMATELY 80 POUNDS PER ACRE).
- WHERE STRAW MULCH FOR TEMPORARY EROSION CONTROL IS REQUIRED, IT SHALL BE APPLIED AT A MINIMUM THICKNESS OF THREE (3) INCHES OR 3,000 LBS/ACRE.
- AS CONSTRUCTION PROGRESSES AND UNEXPECTED SEASONAL CONDITIONS DICTATE, AND AS THE CITY REQUIRES, THE PERMITTEE SHOULD ANTICIPATE THAT MORE TESC MEASURES WILL BE NECESSARY TO PROTECT ADJACENT PROPERTIES AND ENSURE MINIMUM WATER QUALITY FOR SITE RUNOFF. IT SHALL BE THE RESPONSIBILITY OF THE PERMITTEE TO ADDRESS DEFICIENT TESC CONDITIONS AND PROVIDE ADDITIONAL FACILITIES, OVER AND ABOVE MINIMUM REQUIREMENTS OUTLINED ON THE APPROVED PLANS.
- FILTER FABRIC FENCE SHALL BE USED WHERE NOTED ON THE PLANS OR AS DIRECTED BY THE CITY.

CALL 48 HOURS BEFORE YOU DIG  
1-800-424-5555  
OR CALL 8-1-1

**ECTYPOS ARCHITECTURE**

4212 W. Mercer Way  
Mercer Island, WA 98040  
t. (206) 232-9147  
f. (206) 275-0312



Civil Engineer:  
WR Consulting, Inc.  
3611 45th Ave W.  
Seattle, WA 98199  
P: 206.285.1593

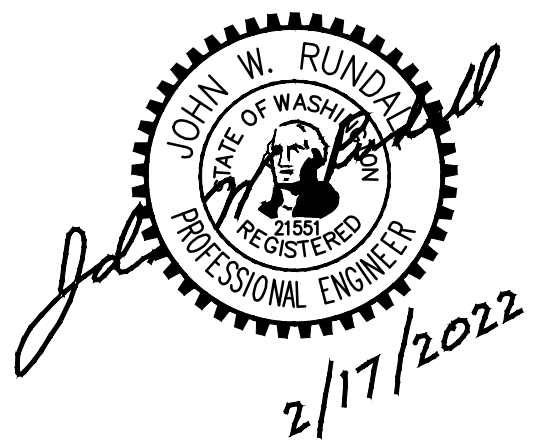

**STEINBORN RESIDENCE**

New Residence  
8435 SE 47th Pl.  
Mercer Island, WA 98040

**PROJECT ADDRESS:**

8435 SE 47th Place, Mercer Island, WA 98040

**LEGAL DESCRIPTION:**

LOT 4, HILL HIGH ESTATES AS RECORDED IN VOLUME 68 OF PLATS, PAGE 28, RECORDS OF KING COUNTY, WASHINGTON.

SITUATE IN THE COUNTY OF KING, STATE OF WASHINGTON.

**PARCEL NUMBER:**

331750-0040

**LOT AREA:**

19,361 SF

Date:  
**2/17/2022 Permit Set**

Scale: As Noted

Sheet: 1 of 4

GENERAL NOTES

C1

CALL 48 HOURS  
BEFORE YOU DIG  
1-800-424-5555  
OR CALL 8-1-1

**ECTYPOS**  
ARCHITECTURE

4212 W. Mercer Way  
Mercer Island, WA 98040  
t. (206) 232-9147  
f. (206) 275-0312

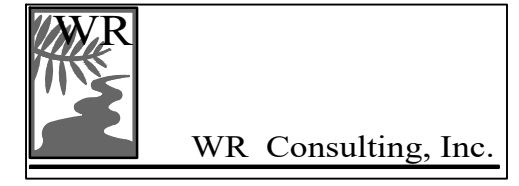

Civil Engineer:  
WR Consulting, Inc.  
3611 45th Ave W.  
Seattle, WA 98199  
P: 206.285.1593

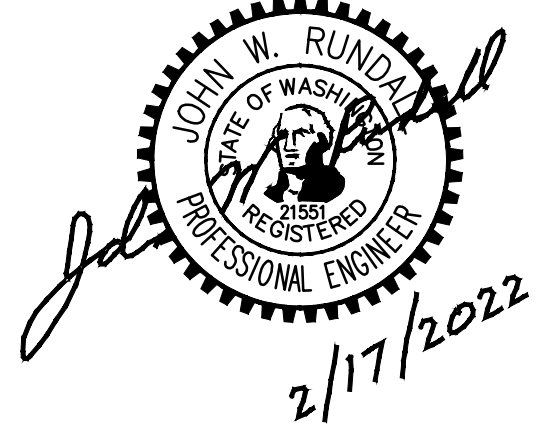

**TREE PROTECTION NOTES:**

1. ALL TREES NOT INDICATED FOR REMOVAL SHALL REMAIN UNDISTURBED.
2. INSTALL ADDITIONAL TREE PROTECTION FENCING AS NEEDED TO PREVENT DAMAGE TO EXISTING TREES.
3. EXCESS EXCAVATED MATERIALS SHALL NOT BE DISPOSED OF ON-SITE OR PLACED ON ANY ROOT ZONE OF EXISTING TREES TO REMAIN.
4. SPOILS, EXCESS MATERIALS AND CONSTRUCTION DEBRIS SHALL BE REMOVED FROM THE HILLSIDE AND DISPOSED OF IN ACCORDANCE WITH STATE AND LOCAL REQUIREMENTS.

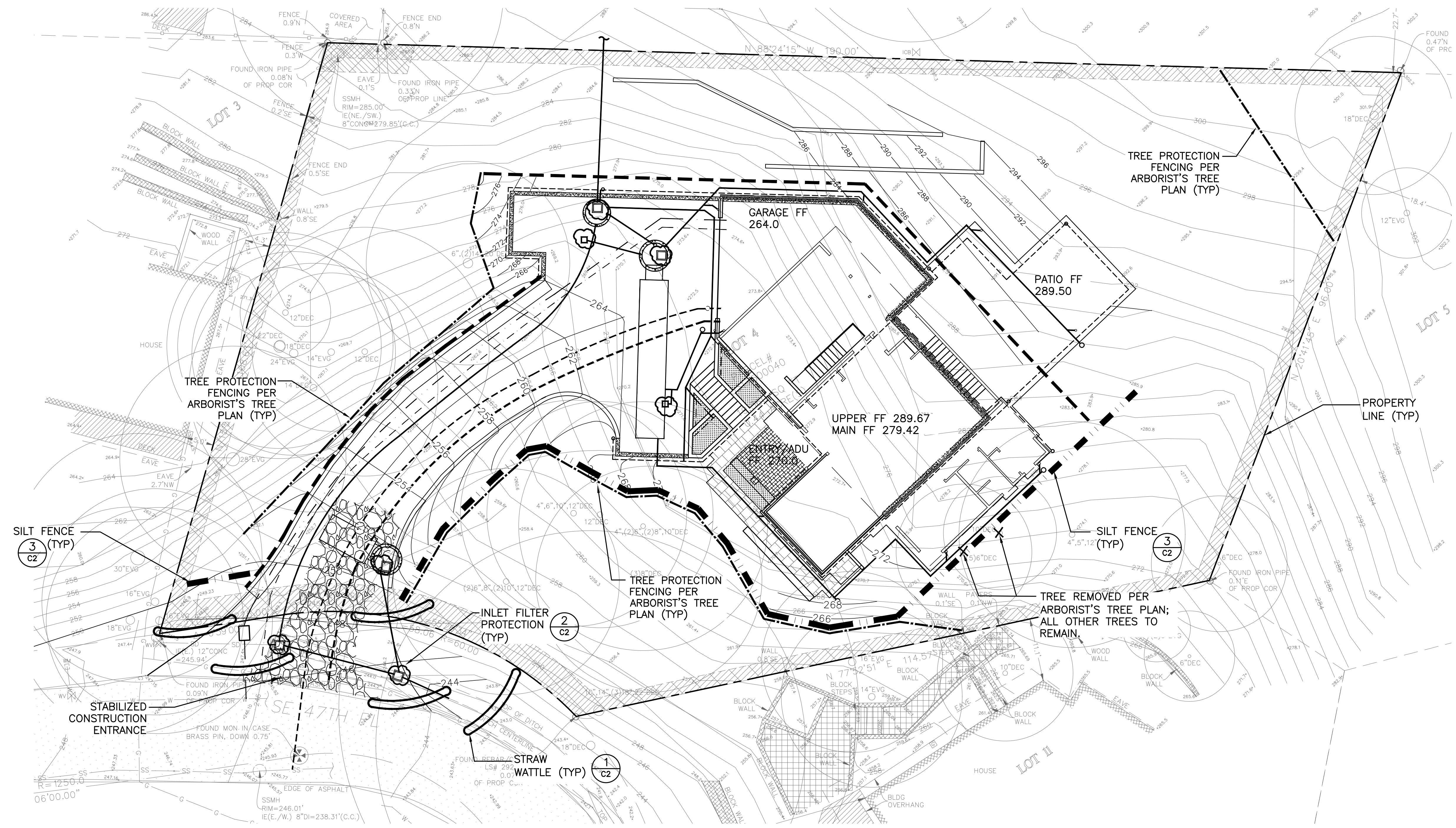

**LEGEND**

- INLET PROTECTION
- REMOVE TREE X
- SILT FENCE
- STRAW WATTLE/COIR LOG
- STABILIZED CONSTRUCTION ENTRANCE
- TREE PROTECTION FENCE

- WATTLE DETAIL NOTES**
1. Install Wattles along contours. Installation shall be in accordance with Standard Specification 8-01.3(10).
  2. Securely knot each end of Wattle. Abut adjacent Wattles tightly, end to end, without overlapping the ends.
  3. Pilot holes may be driven through the Wattles and into the soil when soil conditions require.
  4. Live stakes may be used for Permanent installation and shall be in accordance with Standard Specification 9-14.6.
  5. Wattles shall be inspected regularly, and immediately after a rainfall produces runoff, to ensure they remain thoroughly entrenched and in contact with the soil.

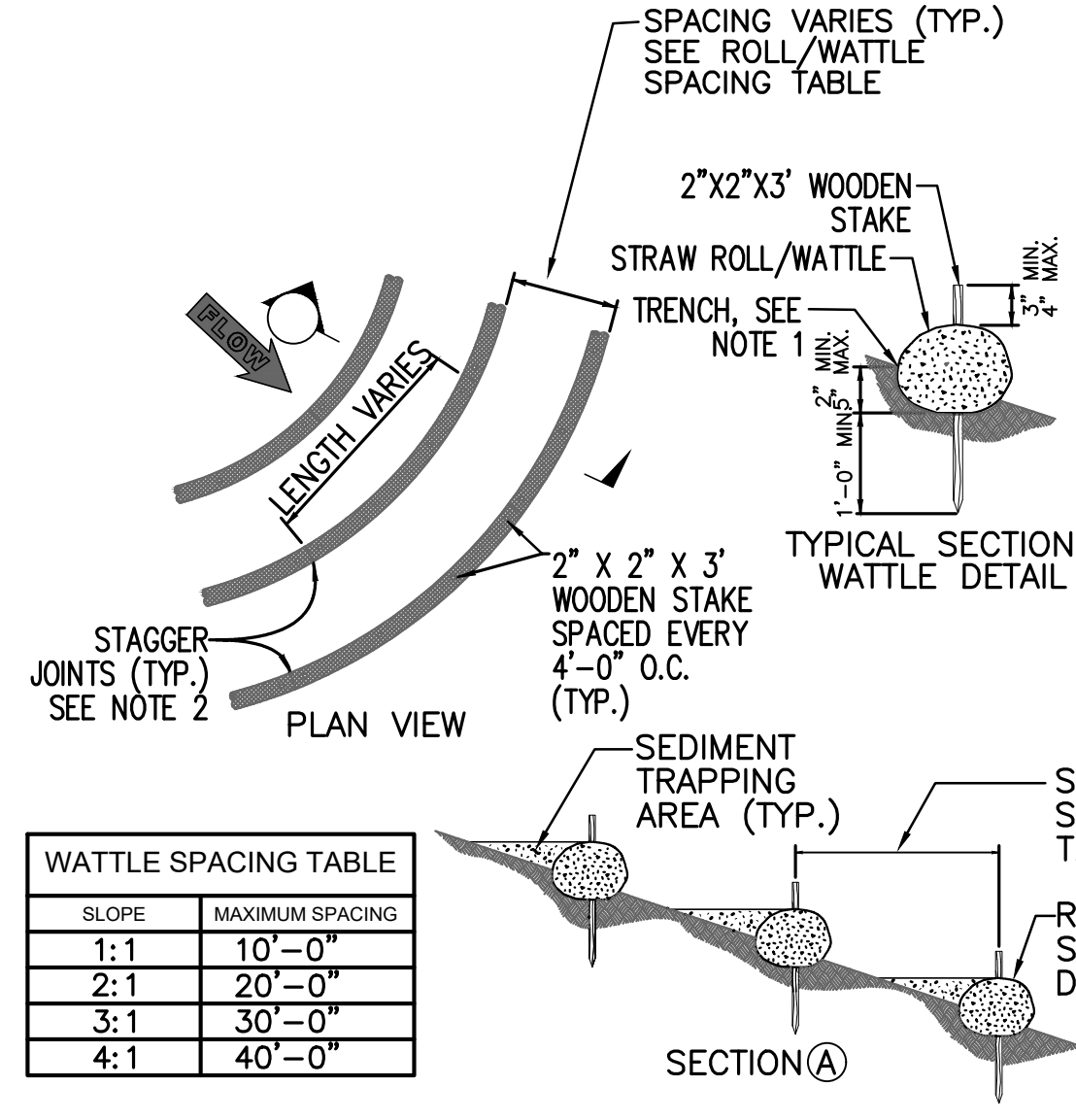
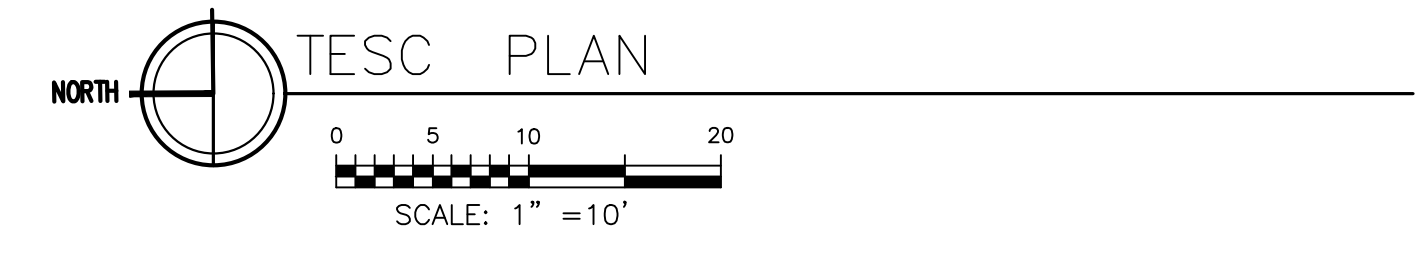

WATTLE SPACING TABLE	
SLOPE	MAXIMUM SPACING
1:1	10'-0"
2:1	20'-0"
3:1	30'-0"
4:1	40'-0"

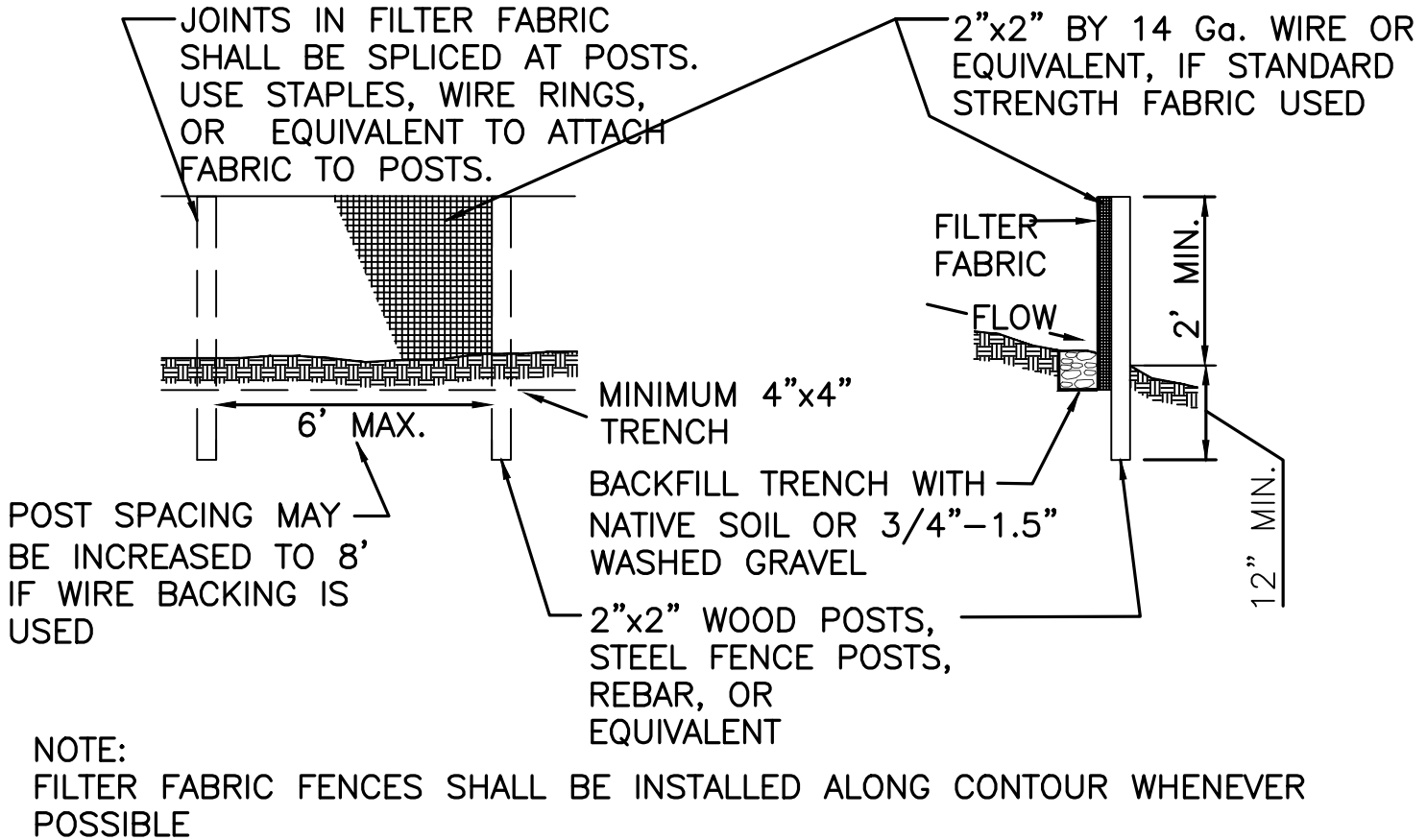
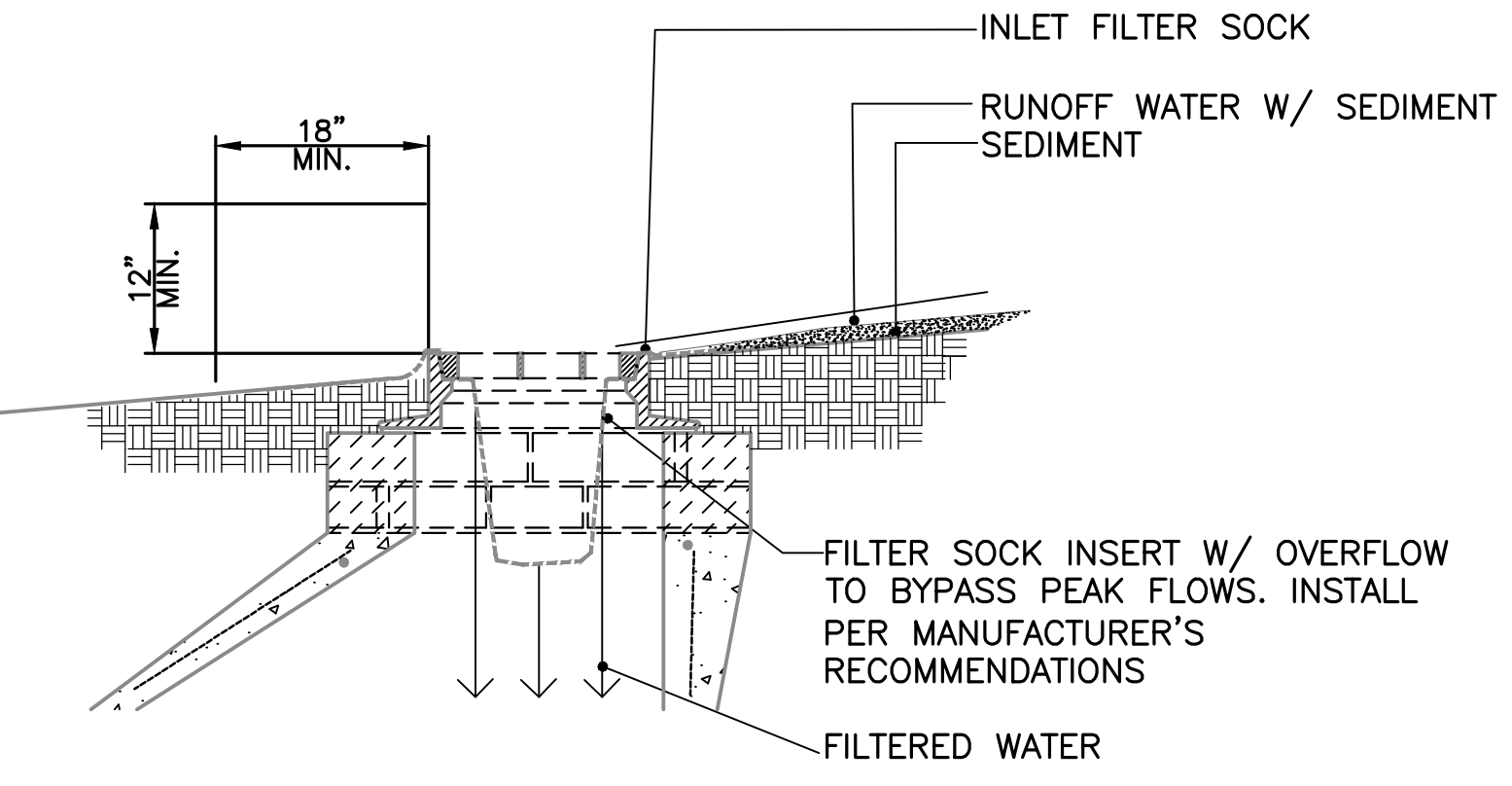

**TESC SEASONAL WAIVER NOTES:**

1. DURING CONSTRUCTION OF DETENTION SYSTEM OR OTHER SITE WORK, A STORMWATER MANAGEMENT FACILITY INCLUDING STORAGE (EG. BAKER TANKS), PUMPS, TREATMENT COMPONENTS AND SETTLING MEASURES SHALL BE IN PLACE AS NEEDED TO CONTROL SEDIMENT WHEN DISCHARGING STORMWATER TO THE STORM DRAIN SYSTEM.
2. THE STORMWATER MANAGEMENT FACILITY SHALL BE MAINTAINED AND OPERATED AS REQUIRED TO PREVENT THE DISCHARGE OF SEDIMENT LADEN SOILS FROM THE SITE.

Date: **2/17/2022 Permit Set**

Scale: 1" = 10'

Sheet: 2 of 4

TESC PLAN AND DETAILS

**C2**

1 C2 STRAW ROLL (WATTLE) DETAIL SCALE: N.T.S.

2 C2 INLET PROTECTION DETAIL SCALE: N.T.S.

3 C2 SILT FENCE DETAIL SCALE: N.T.S.



**ATTACHMENT 1  
CITY OF MERCER ISLAND  
ON-SITE DETENTION SYSTEM WORKSHEET  
(FOR NEW PLUS REPLACED IMPERVIOUS  
AREA OF 9,500 SF OR LESS)**

**DETENTION TANK NOTES:**

1. THE DETENTION PIPE MATERIAL SHALL BE WATERTIGHT AS OPPOSED TO "SOIL TIGHT".
2. THE DETENTION TANKS SHALL BE ADS N-12 WT (WATERTIGHT) IB PIPE WITH JOINTS IN ACCORDANCE WITH ASTM D3212 LAB TEST AND ASTM F1417 WATERTIGHT FIELD TEST.
3. THE PIPE MATERIAL SELECTED SHALL CONFORM TO THE TESTING REQUIREMENTS IN SECTION 7-17.3(2)F OF THE 2020 WSDOT STANDARD SPECIFICATIONS EXCEPT THE DETENTION PIPE SHALL BE TESTED IN ITS ENTIRETY RATHER THAN ONE JOINT AT A TIME.

OWNER: Dan and Susan Steinborn	ADDRESS: 8435 SE 47th PLACE	PREPARED BY: JOHN W. RUNDALL, P.E.
PERMIT #:	MERCER ISLAND, WA	PHONE: 206-850-1686
NEW PLUS REPLACED IMPERVIOUS SURFACE AREA (SF): 5,768 SF	DETENTION PIPE DIA (INCH): 60" ø	DETENTION PIPE LENGTH (FT): 37
SOIL TYPE: TYPE D	PIPE MATERIAL: ADS N-12 WT IB PIPE W/WATERTIGHT JOINTS	ORIFICE #1 DIA SEE TABLES BELOW: ORIFICE #2 DIA

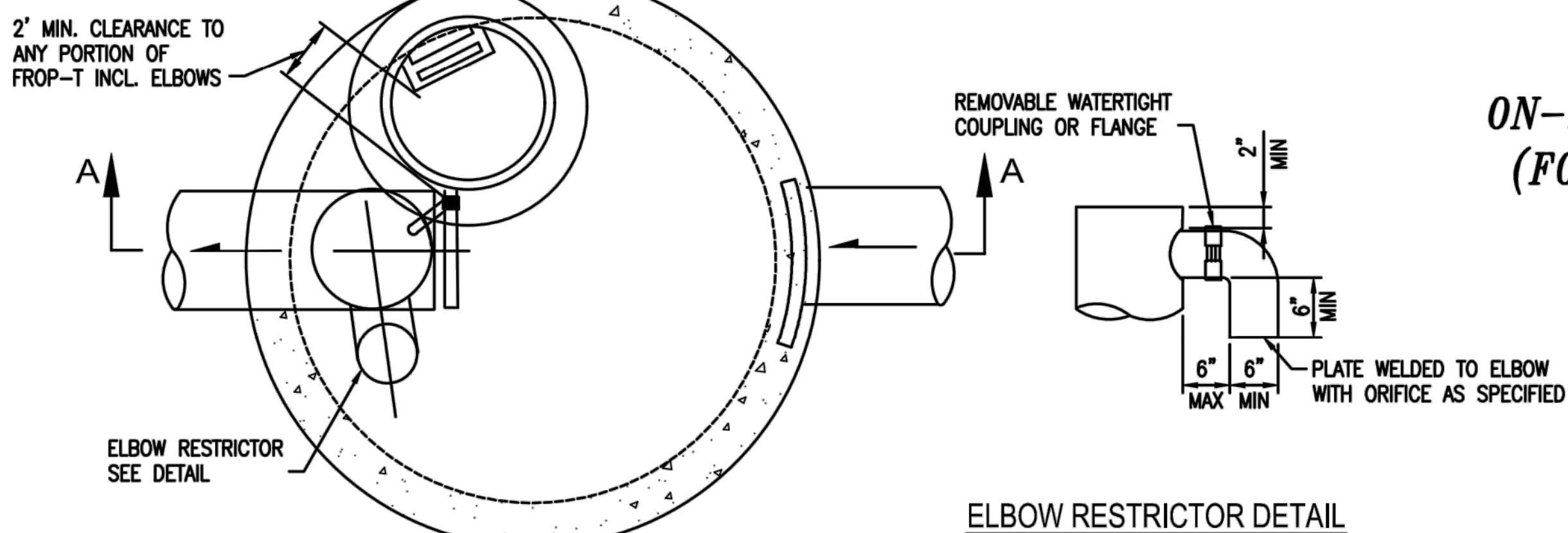

**ELBOW RESTRICTOR DETAIL**

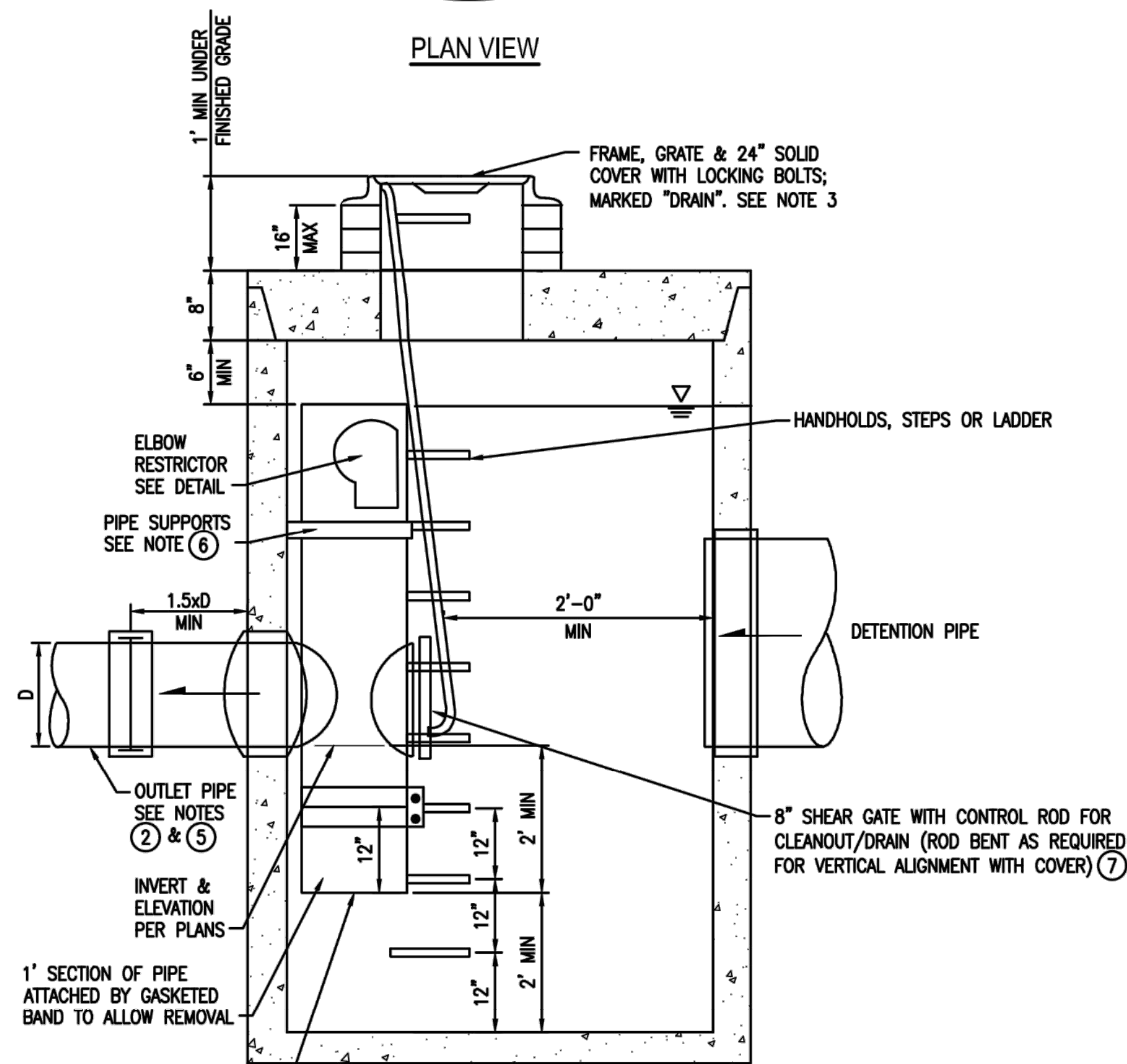

**SECTION A-A  
CONTROL STRUCTURE DETAIL  
NOT TO SCALE**

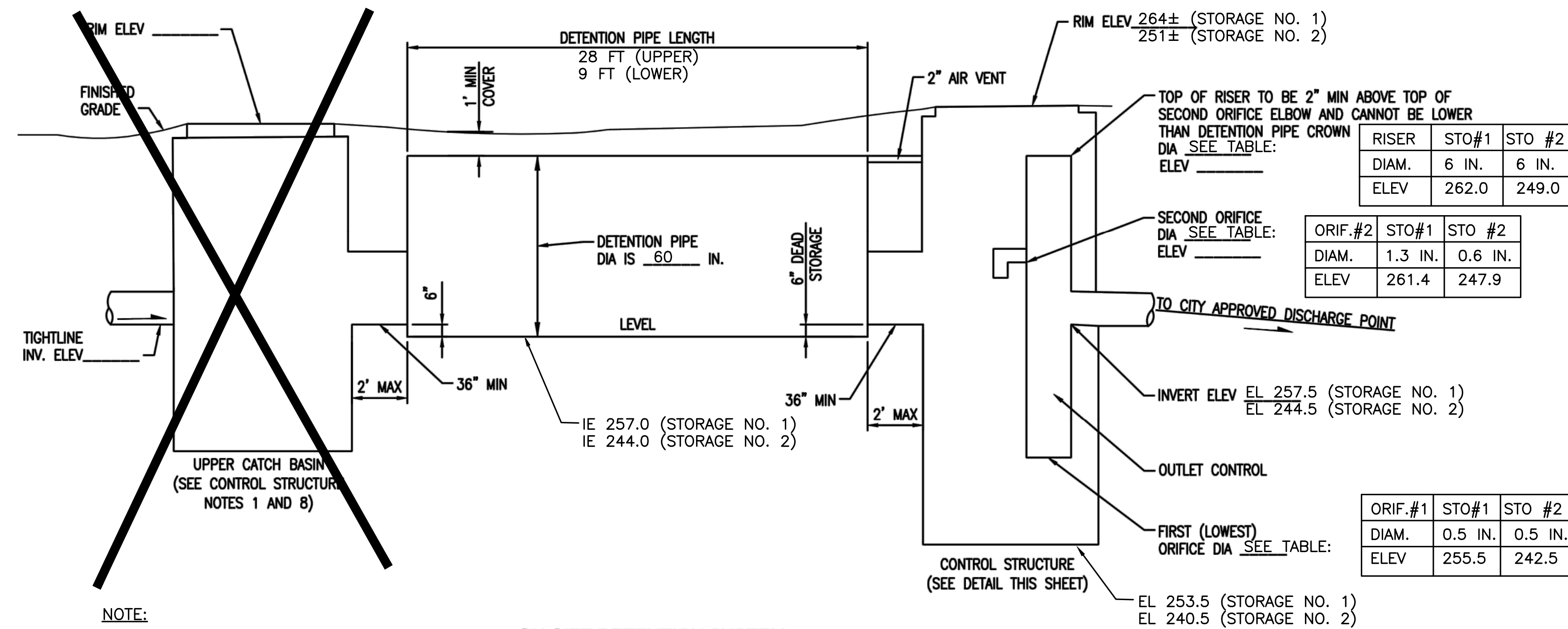

**ON-SITE DETENTION SYSTEM  
NOT TO SCALE (ENGINEER TO FILL IN BLANKS)**

- NOTE:**
1. UPPER CB NOT REQUIRED FOR EITHER STORAGE TANK PER CONTROL STRUCTURE NOTES, NOTE #8.

**CONTROL STRUCTURE NOTES:**

1. USE A MINIMUM OF A 54 IN. DIAM. TYPE 2 CATCH BASIN. THE ACTUAL SIZE IS DEPENDENT ON CONNECTING PIPE MATERIAL AND DIAMETER.
2. OUTLET PIPE: MIN. 6 INCH.
3. METAL PARTS: CORROSION RESISTANT. NON-GALVANIZED PARTS PREFERRED. GALVANIZED PIPE PARTS TO HAVE ASPHALT TREATMENT 1.
4. FRAME AND LADDER OR STEPS OFFSET SO:
  - A. CLEANOUT GATE IS VISIBLE FROM TOP;
  - B. CLIMB-DOWN SPACE IS CLEAR OF RISER AND CLEANOUT GATE;
  - C. FRAME IS CLEAR OF CURB.
5. IF METAL OUTLET PIPE CONNECTS TO CEMENT CONCRETE PIPE, OUTLET PIPE TO HAVE SMOOTH O.D. EQUAL TO CONCRETE PIPE I.D. LESS 1/4 IN.
6. PROVIDE AT LEAST ONE 3 X 0.090 GAUGE SUPPORT BRACKET ANCHORED TO CONCRETE WALL WITH 5/8 IN. STAINLESS STEEL EXPANSION BOLTS OR EMBEDDED SUPPORTS 2 IN. INTO CATCH BASIN WALL (MAXIMUM 3'-0" VERTICAL SPACING).
7. THE SHEAR GATE SHALL BE MADE OF ALUMINUM ALLOY IN ACCORDANCE WITH ASTM B 26M AND ASTM B 275, DESIGNATION ZG32A; OR CAST IRON IN ACCORDANCE WITH ASTM A 48, CLASS 30B. THE LIFT HANDLE SHALL BE MADE OF A SIMILAR METAL TO THE GATE (TO PREVENT GALVANIC CORROSION), IT MAY BE OF SOLID ROD OR HOLLOW TUBING, WITH ADJUSTABLE HOOK AS REQUIRED. A NEOPRENE RUBBER GASKET IS REQUIRED BETWEEN THE RISER MOUNTING FLANGE AND THE GATE FLANGE. INSTALL THE GATE SO THAT THE LEVEL-LINE MARK IS LEVEL WHEN THE GATE IS CLOSED. THE MATING SURFACES OF THE LID AND THE BODY SHALL BE MACHINED FOR PROPER FIT. ALL SHEAR GATE BOLTS SHALL BE STAINLESS STEEL.
8. THE UPPER CATCH BASIN IS REQUIRED IF THE LENGTH OF THE DETENTION PIPE IS GREATER THAN 50 FT.

**ON-SITE DETENTION SYSTEM NOTES:**

1. CALL DEVELOPMENT SERVICES (206-275-7605) 24 HOURS IN ADVANCE FOR A DETENTION SYSTEM INSPECTION BEFORE BACKFILLING AND FOR FINAL INSPECTIONS.
2. RESPONSIBILITY FOR OPERATION AND MAINTANANCE OF DRAINAGE SYSTEMS ON PRIVATE PROPERTY IS RESPONSIBILITY OF THE PROPERTY OWNER. MATERIAL ACCUMULATED IN THE STORAGE PIPE MUST BE REMOVED FROM CATCH BASINS TO ALLOW PROPER OPERATION. THE OUTLET CONTROL ORIFICE MUST BE KEPT OPEN AT ALL TIMES.
3. PIPE MATERIAL, JOINT, AND PROTECTIVE TREATMENT SHALL BE IN ACCORDANCE WITH SECTION 7.04 AND 9.05 OF THE WSDOT STANDARD SPECIFICATION FOR ROAD, BRIDGE, AND MUNICIPAL CONSTRUCTION, LATEST VERSION. SUCH MATERIALS INCLUDE THE FOLLOWING, LINED CORRUGATED POLYETHYLENE PIPE (LCPE), ALUMINIZED TYPE 2 CORRUGATED STEEL PIPE AND PIPE ARCH (MEETS AASHTO DESIGNATIONS M274 AND M36), CORRUGATED OR SPIRAL RIB ALUMINUM PIPE, OR REINFORCED CONCRETE PIPE. CORRUGATED STEEL PIPE IS NOT ALLOWED.
4. FOOTING DRAINS SHALL NOT BE CONNECTED TO THE DETENTION SYSTEM.

Date: 2/17/2022 Permit Set

Scale: As Noted

Sheet: 4 of 4

DETENTION TANK DETAILS

# Appendix C

## Stormwater Pollution Prevention Plan (SWPPP)

# Stormwater Pollution Prevention Plan

**For**  
Steinborn Residence ~

**Prepared For**  
City of Mercer Island  
Development Services Group  
9611 SE 36<sup>th</sup> Street  
Mercer Island WA 98040  
206-275-7605

**Owner**  
Daniel and Susan Steinborn~  
8435 SE 47<sup>th</sup> Place  
Mercer Island, WA 98040~

**Operator/Contractor**  
Mercer Builders~  
3026 78<sup>th</sup> Ave SE  
Mercer Island, WA 98040~

~

~

~

**Project Site Location**  
8435 SE 47<sup>th</sup> Place  
Mercer Island, WA 98040

**Certified Erosion and Sediment Control Lead**  
TBD – See Contractor~

~

**SWPPP Prepared By**  
John W. Rundall, P.E.  
WR Consulting, Inc.  
3611 45<sup>th</sup> Avenue West  
Seattle, WA 98199  
(206) 850-1686~

~~

**SWPPP Preparation Date**  
February 12, 2022

**Approximate Project Construction Dates**  
June 2022~

~

## Contents

1.0 Introduction.....	1
2.0 Site Description .....	3
2.1 Existing Conditions .....	3
2.2 Proposed Construction Activities.....	3
3.0 Stormwater BMPs.....	4
3.1 Construction: The 12 BMP Elements.....	4
3.1.1 Element #1 – Mark Clearing Limits .....	4
3.1.2 Element #2 – Establish Construction Access .....	4
3.1.3 Element #3 – Control Flow Rates.....	5
3.1.4 Element #4 – Install Sediment Controls .....	5
3.1.5 Element #5 – Stabilize Soils.....	6
3.1.6 Element #6 – Protect Slopes.....	7
3.1.7 Element #7 – Protect Drain Inlets.....	8
3.1.8 Element #8 – Stabilize Channels and Outlets.....	8
3.1.9 Element #9 – Control Pollutants.....	9
3.1.10 Element #10 – Control Dewatering.....	11
3.1.11 Element #11 – Maintain BMPs .....	12
3.1.12 Element #12 – Manage the Project.....	12
3.2 Site Specific Construction BMPs .....	14
3.3 Additional Advanced BMPs.....	14
4.0 Construction Phasing and BMP Implementation .....	16
5.0 Pollution Prevention Team .....	17
5.1 Roles and Responsibilities.....	17
5.2 Team Members.....	18
6.0 Site Inspections and Monitoring.....	19
6.1 Site Inspection .....	19
6.1.1 Site Inspection Frequency .....	20
6.1.2 Site Inspection Documentation.....	20
6.2 Stormwater Quality Monitoring .....	20
6.2.1 Turbidity Sampling.....	20
6.2.2 pH Sampling and Monitoring.....	21
6.3 Stormwater Facilities Maintenance and Operation .....	22
6.3.1 Conveyance System.....	22
6.3.2 Pumping Facility, Bioretention and Permeable Pavement .....	23
7.0 Reporting and Recordkeeping .....	24
7.1 Recordkeeping.....	24
7.1.1 Site Log Book.....	24



7.1.2	Records Retention.....	24
7.1.3	Access to Plans and Records .....	24
7.1.4	Updating the SWPPP .....	24
7.2	Reporting .....	25
7.2.1	Discharge Monitoring Reports .....	25
7.2.2	Notification of Noncompliance .....	25
7.2.3	Permit Application and Changes .....	25

**Appendix A Site plans**

- Vicinity map
- Site Plan and TESC measures (Sheets C2 and C3)

**Appendix B Construction BMPs**

- Reference from DOE Stormwater Manual, Vol. 2, Construction Stormwater Pollution Prevention Best Management Practices (BMPs)

**Appendix C Alternative Construction BMP list**

- List of BMPs not selected, but can be referenced if needed in each of the 12 elements

**Appendix D Site Log and Inspection Forms****Appendix E Engineering Calculations**

- Not Applicable

## 1.0 Introduction

This Stormwater Pollution Prevention Plan (SWPPP) has been prepared as part of the NPDES stormwater permit requirements for the construction project on Mercer Island, Washington. The site is located at 8435 SE 47<sup>th</sup> Place. The site is 19,361 square feet and is undeveloped. The improvements for this project are for building a single family residence and access driveway, stormwater controls for the new and replaced impervious and site restoration.

Construction activities will include excavation, soil/slope stabilization measures, grading, installation of stormwater facilities, construction of the new house, paving, soil restoration and final removal of construction stormwater BMPs. The purpose of this SWPPP is to describe the proposed construction activities and all temporary and permanent erosion and sediment control (TESC) measures, pollution prevention measures, inspection/monitoring activities, and recordkeeping that will be implemented during the proposed construction project and for the maintenance of the completed facility. The objectives of the SWPPP are to:

1. Implement Best Management Practices (BMPs) to prevent erosion and sedimentation, and to identify, reduce, eliminate or prevent stormwater contamination and water pollution from construction activity.
2. Prevent violations of surface water quality, ground water quality, or sediment management standards.
3. Prevent, during and after the construction phase, adverse water quality impacts including impacts on beneficial uses of the receiving water by controlling peak flow rates and volumes of stormwater runoff at the Permittee's outfalls and downstream of the outfalls.

This SWPPP was prepared using the Ecology SWPPP Template downloaded from the Ecology website. This SWPPP was prepared based on the requirements set forth in the Construction Stormwater General Permit, Stormwater Management Manual for Western Washington (SWMMWW 2014) The report is divided into seven main sections with several appendices that include stormwater related reference materials. The topics presented in the each of the main sections are:

- Section 1 – INTRODUCTION. This section provides a summary description of the project, and the organization of the SWPPP document.
- Section 2 – SITE DESCRIPTION. This section provides a detailed description of the existing site conditions, proposed construction activities, and calculated stormwater flow rates for existing conditions and post–construction conditions.

- Section 3 – STORMWATER BMPs. This section provides a detailed description of the BMPs to be implemented based on the 12 required elements of the SWPPP and Source Control BMPs for the operation of the facilities on-site.
- Section 4 – CONSTRUCTION PHASING AND BMP IMPLEMENTATION. This section provides a description of the timing of the BMP implementation in relation to the project schedule.
- Section 5 – POLLUTION PREVENTION TEAM. This section identifies the appropriate contact names (emergency and non-emergency), monitoring personnel, and the onsite temporary erosion and sedimentation control inspector
- Section 6 – INSPECTION AND MONITORING. This section provides a description of the inspection and monitoring requirements such as the parameters of concern to be monitored, sample locations, sample frequencies, and sampling methods for all stormwater discharge locations from the site as well as long term maintenance of the stormwater facilities.
- Section 7 – RECORDKEEPING. This section describes the requirements for documentation of the BMP implementation, site inspections, monitoring results, and changes to the implementation of certain BMPs due to site factors experienced during construction.

Supporting documentation and standard forms are provided in the following Appendices:

Appendix A – Site plans  
Appendix B – Construction BMPs  
Appendix C – Alternative Construction BMP list  
Appendix D – Site Log and Inspection Forms  
Appendix E – Engineering Calculations

---

## 2.0 Site Description

### 2.1 Existing Conditions

The proposed building site is located at 8435 SE 47<sup>th</sup> Place, Mercer Island, WA. A site vicinity map and coordinates are provided in Appendix A. The site is 19,361 square feet and development includes a single family residence, access driveways and landscaped areas. The topography of the site and surrounding properties slopes to the south property line.

Runoff from the site drains south and is collected a roadside ditch on the north side of SE 47<sup>th</sup> Place.

### 2.2 Proposed Construction Activities

The proposed development includes the construction of stormwater collection and conveyance system, and a detention facility that will provide on-site stormwater management for runoff from the new impervious surfaces for the project.

Construction activities will include site preparation, TESC installation, soil stabilization by soil nailing, excavation for the building and driveway structures, grading for the drainage facilities, soil restoration and removal of construction BMPs. The schedule and phasing of BMPs during construction is provided in Section 4.0.

The following summarizes details regarding site areas:

- Total site area: 19,361 sf or 0.44 acres
- Disturbed area during construction: 8,308 sf or 0.19 acre
- Disturbed area that is characterized as impervious (i.e., access roads, staging, excavation, etc): 5,768 sf or 0.13 acre
- Site Soil Restoration area that is pervious: 2,540 sf or 0.06 acres
- Site that is to remain Undisturbed: 11,053 sf or 0.25 acres

## **3.0 Stormwater BMPs**

### **3.1 Construction: The 12 BMP Elements**

#### **3.1.1 Element #1 – Mark Clearing Limits**

To protect adjacent properties and to reduce the area of soil exposed to construction, the limits of construction will be clearly marked before land-disturbing activities begin. Trees that are to be preserved, as well as all sensitive areas and their buffers, shall be clearly delineated, both in the field and on the plans. In general, natural vegetation and native topsoil shall be retained in an undisturbed state to the maximum extent possible. The BMPs relevant to marking the clearing limits that will be applied for this project include:

BMPs to be implemented:

- BMP C101: Preserving Natural Vegetation
- BMP C102: Buffer Zones
- BMP C103: High Visibility Fence

Clearing limits will be marked to control access to the area of the site that is to remain undisturbed and protect existing plantings.

Alternate BMPs for marking clearing limits are included in Appendix C as a quick reference tool for the onsite inspector in the event the BMP(s) listed above are deemed ineffective or inappropriate during construction to satisfy the requirements set forth in the General NPDES Permit. To avoid potential erosion and sediment control issues that may cause a violation(s) of the NPDES Construction Stormwater permit, the Certified Erosion and Sediment Control Lead will promptly initiate the implementation of one or more of the alternative BMPs listed in Appendix C after the first sign that existing BMPs are ineffective or failing.

#### **3.1.2 Element #2 – Establish Construction Access**

Construction access or activities occurring on unpaved areas shall be minimized, yet where necessary, access points shall be stabilized to minimize the tracking of sediment onto public roads, and wheel washing, street sweeping, and street cleaning shall be employed to prevent sediment from entering state waters. All wash wastewater shall be controlled on site. The specific BMPs related to establishing construction access that will be used on this project include:

- A stabilized construction access BMP (BMP C107) will be constructed at the site entrance and will remain in-place during the construction of the new facilities to help control erosion from the site. Wheel washing in accordance with BMP C106, Wheel Wash will be implemented as needed.

Alternate construction access BMPs are included in Appendix C as a quick reference tool for the onsite inspector in the event the BMP(s) listed above are deemed ineffective or inappropriate

during construction to satisfy the requirements set forth in the General NPDES Permit. To avoid potential erosion and sediment control issues that may cause a violation(s) of the NPDES Construction Stormwater permit, the Certified Erosion and Sediment Control Lead will promptly initiate the implementation of one or more of the alternative BMPs listed in Appendix C after the first sign that existing BMPs are ineffective or failing.

### **3.1.3 Element #3 – Control Flow Rates**

In order to protect the properties and waterways downstream of the project site, stormwater discharges from the site will be controlled. The specific BMPs for flow control that shall be used on this project include:

No temporary construction BMPs to be implemented however, when the flow control facility is completed, it will be used to control runoff from the site

- BMP C241 will be provided by the flow control facility. If used for flow control and sediment containment during construction, the Detention Tank shall be thoroughly cleaned after construction is complete and the site is stabilized.

Alternate flow control BMPs are included in Appendix C as a quick reference tool for the onsite inspector in the event the BMP(s) listed above are deemed ineffective or inappropriate during construction to satisfy the requirements set forth in the General NPDES Permit. To avoid potential erosion and sediment control issues that may cause a violation(s) of the NPDES Construction Stormwater permit, the Certified Erosion and Sediment Control Lead will promptly initiate the implementation of one or more of the alternative BMPs listed in Appendix C after the first sign that existing BMPs are ineffective or failing.

In general, discharge rates of stormwater from the site will be controlled where increases in impervious area or soil compaction during construction could lead to downstream erosion, or where necessary to meet local agency stormwater discharge requirements.

### **3.1.4 Element #4 – Install Sediment Controls**

All stormwater runoff from disturbed areas shall pass through an appropriate sediment removal BMP before leaving the construction site or prior to being discharged to an infiltration facility. The specific BMPs to be used for controlling sediment on this project include:

- Silt Fences (BMP C233), and Straw Wattles (BMP C235), will be used throughout the site to control erosion and prevent sediment laden waters from leaving the site.
- Most of the earth grading work will be completed during the dryer summer months to reduce the risk of erosion during rainfall events.

Alternate sediment control BMPs are included in Appendix C as a quick reference tool for the onsite inspector in the event the BMP(s) listed above are deemed ineffective or inappropriate during construction to satisfy the requirements set forth in the General NPDES Permit. To avoid potential erosion and sediment control issues that may cause a violation(s) of the NPDES Construction Stormwater permit the Certified Erosion and Sediment Control Lead will promptly initiate the implementation of one or more of the alternative BMPs listed in Appendix C after the first sign that existing BMPs are ineffective or failing.

In addition, sediment will be removed from paved areas in and adjacent to construction work areas manually or using mechanical sweepers, as needed, to minimize tracking of sediments on vehicle tires away from the site and to minimize washoff of sediments from adjacent streets in runoff.

Whenever possible, sediment laden water shall be discharged into onsite, relatively level, vegetated areas (BMP C240).

In some cases, sediment discharge in concentrated runoff can be controlled using permanent stormwater BMPs (e.g., infiltration swales, ponds, trenches). Sediment loads can limit the effectiveness of some permanent stormwater BMPs, such as those used for infiltration or biofiltration; however, those BMPs designed to remove solids by settling (wet ponds or detention ponds) can be used during the construction phase. When permanent stormwater BMPs will be used to control sediment discharge during construction, the structure will be protected from excessive sedimentation with adequate erosion and sediment control BMPs. Any accumulated sediment shall be removed after construction is complete and the permanent stormwater BMP will be restabilized with vegetation per applicable design requirements once the remainder of the site has been stabilized.

### **3.1.5 Element #5 – Stabilize Soils**

Exposed and unworked soils shall be stabilized with the application of effective BMPs to prevent erosion throughout the life of the project. The specific BMPs for soil stabilization that shall be used on this project include:

- Temporary seeding (BMP 120) will be applied on exposed soils that will remain exposed for longer periods or sufficient period of time for the temporary seeding to become established.
- Arborist's mulch or compost (BMP C121) will be placed on exposed soils where longer periods of exposure are expected. Arborist's mulch and compost are also the preferred stabilization method in areas that will be planted so the temporary material may be tilled into the soils and provide further amendment before planting.

- Plastic Sheetting (BMP C123) will be applied to stockpiled soils or other small areas requiring stabilization and prevent erosion during rainfall events for short periods of time.
- Surface roughening (BMP C130) will also be provided as needed for soil stabilization.
- Dust control (BMP C140) will be provided by spraying water to moisten and stabilize soils.
- These BMPs will be implemented in graded areas that are temporarily not worked due to phasing or focus of work on other areas of the site. The BMP will be selected to best fit the expected duration of need and to support the subsequent phase of construction.

Alternate soil stabilization BMPs are included in Appendix C as a quick reference tool for the onsite inspector in the event the BMP(s) listed above are deemed ineffective or inappropriate during construction to satisfy the requirements set forth in the General NPDES Permit. To avoid potential erosion and sediment control issues that may cause a violation(s) of the NPDES Construction Stormwater permit, the Certified Erosion and Sediment Control Lead will promptly initiate the implementation of one or more of the alternative BMPs listed in Appendix C after the first sign that existing BMPs are ineffective or failing.

The project site is located west of the Cascade Mountain Crest. As such, no soils shall remain exposed and unworked for more than 7 days during the dry season (May 1 to September 30) and 2 days during the wet season (October 1 to April 30). Regardless of the time of year, all soils shall be stabilized at the end of the shift before a holiday or weekend if needed based on weather forecasts.

In general, cut and fill slopes will be stabilized as soon as possible and soil stockpiles will be temporarily covered with plastic sheeting. All stockpiled soils shall be stabilized from erosion, protected with sediment trapping measures, and where possible, be located away from storm drain inlets, waterways, and drainage channels.

### **3.1.6 Element #6 – Protect Slopes**

All cut and fill slopes will be designed, constructed, and protected in a manner than minimizes erosion. The following specific BMPs will be used to protect slopes for this project:

In addition to the BMPs implemented as outlined in Section 3.1.5 the following BMPs may be used to reduce runoff and erosion on steep slopes:

- BMP C122 – Nets and Blankets
- BMP C231 Brush Barrier



- BMP C233: Silt Fence
- BMP C235: Straw Wattles

Alternate slope protection BMPs are included in Appendix C as a quick reference tool for the onsite inspector in the event the BMP(s) listed above are deemed ineffective or inappropriate during construction to satisfy the requirements set forth in the General NPDES Permit. To avoid potential erosion and sediment control issues that may cause a violation(s) of the NPDES Construction Stormwater permit, the Certified Erosion and Sediment Control Lead will promptly initiate the implementation of one or more of the alternative BMPs listed in Appendix C after the first sign that existing BMPs are ineffective or failing.

### **3.1.7 Element #7 – Protect Drain Inlets**

All storm drain inlets and culverts made operable during construction shall be protected to prevent unfiltered or untreated water from entering the drainage conveyance system. However, the first priority is to keep all access roads clean of sediment and keep street wash water separate from entering storm drains until treatment can be provided. Storm Drain Inlet Protection (BMP C220) will be implemented for all drainage inlets and culverts that could potentially be impacted by sediment-laden runoff on and near the project site. The following inlet protection measures will be applied on this project:

- Storm Drain Inlet Protection (BMP C220) will be implemented all affected inlets and/or catch basin grates.

If the BMP options listed above are deemed ineffective or inappropriate during construction to satisfy the requirements set forth in the General NPDES Permit, or if no BMPs are listed above but deemed necessary during construction, the Certified Erosion and Sediment Control Lead shall implement one or more of the alternative BMP inlet protection options listed in Appendix C.

### **3.1.8 Element #8 – Stabilize Channels and Outlets**

Where site runoff is to be conveyed in channels, or discharged to a stream or some other natural drainage point, efforts will be taken to prevent downstream erosion. The specific BMPs for channel and outlet stabilization that shall be used on this project include:

- TBMP C209 – Outlet Protection will be installed if needed and additional check dams (BMP C207) and straw wattles (BMP C235) will be placed in ditches or swales and along steep slopes for stabilization. When completed, the proposed detention facility will reduce peak flow rates, so the need for stabilization channel and outlets is reduced by this work.

Alternate channel and outlet stabilization BMPs are included in Appendix C as a quick reference tool for the onsite inspector in the event the BMP(s) listed above are deemed ineffective or

inappropriate during construction to satisfy the requirements set forth in the General NPDES Permit. To avoid potential erosion and sediment control issues that may cause a violation(s) of the NPDES Construction Stormwater permit, the Certified Erosion and Sediment Control Lead will promptly initiate the implementation of one or more of the alternative BMPs listed in Appendix C after the first sign that existing BMPs are ineffective or failing.

### **3.1.9 Element #9 – Control Pollutants**

All pollutants, including waste materials and demolition debris, that occur onsite shall be handled and disposed of in a manner that does not cause contamination of storm water. Good housekeeping and preventative measures will be taken to ensure that the site will be kept clean, well-organized, and free of debris. If required, BMPs to be implemented to control specific sources of pollutants are discussed below.

Vehicles, construction equipment, and/or petroleum product storage/dispensing:

- All vehicles, equipment, and petroleum product storage/dispensing areas will be inspected regularly to detect any leaks or spills, and to identify maintenance needs to prevent leaks or spills.
- Spill prevention measures, such as drip pans, will be used when conducting maintenance and repair of vehicles or equipment.
- In order to perform emergency repairs on site, temporary plastic will be placed beneath and, if raining, over the vehicle.
- Contaminated surfaces shall be cleaned immediately following any discharge or spill incident.

Chemical storage:

- Any chemicals stored in the construction areas will conform to the appropriate source control BMPs listed in Volume IV of the Ecology stormwater manual. In Western WA, all chemicals shall have cover, containment, and protection provided on site, per BMP C153 for Material Delivery, Storage and Containment in SWMMWW 2014
- Application of agricultural chemicals, including fertilizers and pesticides, shall be conducted in a manner and at application rates that will not result in loss of chemical to stormwater runoff. Manufacturers' recommendations for application procedures and rates shall be followed.

Excavation and tunneling spoils dewatering waste:

- Dewatering BMPs and BMPs specific to the excavation and tunneling (including handling of contaminated soils) are discussed under Element 10.

Demolition:

- Dust released from gravel removal and tilling will be controlled using Dust Control measures (BMP C140).
- Storm drain inlets vulnerable to stormwater discharge carrying dust, soil, or debris will be protected using Storm Drain Inlet Protection (BMP C220 as described above for Element 7).
- Process water and slurry resulting from sawcutting and surfacing operations will be prevented from entering the waters of the State by implementing Sawcutting and Surfacing Pollution Prevention measures (BMP C152).

Concrete and grout:

- Process water and slurry resulting from concrete work will be prevented from entering the waters of the State by implementing Concrete Handling measures (BMP C151).

Sanitary wastewater:

- Portable sanitation facilities will be firmly secured, regularly maintained, and emptied when necessary.
- Wheel wash or tire bath (if used) wastewater shall be discharged to a separate on-site treatment system or to the sanitary sewer as part of Wheel Wash implementation (BMP C106).

Solid Waste:

- Solid waste will be stored in secure, clearly marked containers.

Other:

- Other BMPs will be administered as necessary to address any additional pollutant sources on site.

The facility is not transportation-related and therefore subject to the criteria for determining if a Spill Prevention, Control, and Countermeasure (SPCC) Plan is required under the Federal regulations of the Clean Water Act (CWA).

If a SPCC plan is required for this site it will be prepared per the Federal regulations of the Clean Water Act (CWA) and according to Final Rule 40 CFR Part 112, as stated in the National Register, a Spill Prevention, Control, and Countermeasure (SPCC) Plan is required for construction activities. A SPCC Plan will address an approach to prevent, respond to, and report spills or releases to the environment that could result from construction activities. This Plan must:

- Be well thought out in accordance with good engineering;
- Achieve three objectives - prevent spills, contain a spill that occurs, and clean up the spill;

- Identify the name, location, owner, and type of facility;
- Include the date of initial operation and oil spill history;
- Name the designated person responsible;
- Show evidence of approval and certification by the person in authority;  
and
- Contain a facility analysis.

The facility does not require a Spill Prevention, Control, and Countermeasure (SPCC) Plan under the Federal regulations of the Clean Water Act (CWA).

### **3.1.10 Element #10 – Control Dewatering**

There will be no dewatering from groundwater removal as part of this construction project.

All dewatering water from open cut excavation, tunneling, foundation work, trench, or underground vaults shall be discharged into a controlled conveyance system prior to discharge to a sediment trap or sediment pond. Channels will be stabilized, per Element #8. Clean, non-turbid dewatering water will not be routed through stormwater sediment ponds, and will be discharged to systems tributary to the receiving waters of the State in a manner that does not cause erosion, flooding, or a violation of State water quality standards in the receiving water.

Highly turbid dewatering water from soils known or suspected to be contaminated, or from use of construction equipment, will require additional monitoring and treatment as required for the specific pollutants based on the receiving waters into which the discharge is occurring. Such monitoring is the responsibility of the contractor.

However, the dewatering of soils known to be free of contamination will trigger BMPs to trap sediment and reduce turbidity. At a minimum, geotextile fabric socks/bags/cells will be used to filter this material. Other BMPs to be used for sediment trapping and turbidity reduction include the following:

- Concrete Handling (BMP C151)
- Temporary Sediment Pond (BMP C241)
- Construction Stormwater Chemical Treatment (BMP C250)
- Construction Stormwater Filtration (BMP C 251)
- Infiltration
- Use of a sedimentation bag, with outfall to a ditch or swale for small volumes of localized dewatering.
- Alternative BMP not included in the DOE SWMMWW (2014)

Alternate dewatering control BMPs are included in Appendix C as a quick reference tool for the onsite inspector in the event the BMP(s) listed above are deemed ineffective or inappropriate

during construction to satisfy the requirements set forth in the General NPDES Permit. To avoid potential erosion and sediment control issues that may cause a violation(s) of the NPDES Construction Stormwater permit, the Certified Erosion and Sediment Control Lead will promptly initiate the implementation of one or more of the alternative BMPs listed in Appendix C after the first sign that existing BMPs are ineffective or failing.

### **3.1.11 Element #11 – Maintain BMPs**

All temporary and permanent erosion and sediment control BMPs shall be maintained and repaired as needed to assure continued performance of their intended function. Maintenance and repair shall be conducted in accordance with each particular BMPs specifications (attached). Visual monitoring of the BMPs will be conducted at least once every calendar week and within 24 hours of any stormwater or non-stormwater discharge from the site. If the site becomes inactive, and is temporarily stabilized, the inspection frequency will be reduced to once every month.

All temporary erosion and sediment control BMPs shall be removed within 30 days after the final site stabilization is achieved or after the temporary BMPs are no longer needed. Trapped sediment shall be removed or stabilized on site. Disturbed soil resulting from removal of BMPs or vegetation shall be permanently stabilized.

### **3.1.12 Element #12 – Manage the Project**

Erosion and sediment control BMPs for this project have been designed based on the following principles:

- Design the project to fit the existing topography, soils, and drainage patterns.
- Emphasize erosion control rather than sediment control.
- Minimize the extent and duration of the area exposed.
- Keep runoff velocities low.
- Retain sediment on site.
- Thoroughly monitor site and maintain all ESC measures.
- Schedule major earthwork during the dry season.

As this project site is located west of the Cascade Mountain Crest, the project will be managed according to the following key project components:

#### **Phasing of Construction**

- The construction project is being phased to the extent practicable in order to prevent soil erosion, and, to the maximum extent possible, the transport of sediment from the site during construction.

- Re-vegetation of exposed areas and maintenance of that vegetation shall be an integral part of the clearing activities during each phase of construction, per the Scheduling BMP (C 162).

#### Seasonal Work Limitations

- From October 1 through April 30, clearing, grading, and other soil disturbing activities shall only be permitted if shown to the satisfaction of the local permitting authority that silt-laden runoff will be prevented from leaving the site through a combination of the following:
  - Site conditions including existing vegetative coverage, slope, soil type, and proximity to receiving waters; and
  - Limitations on activities and the extent of disturbed areas; and
  - Proposed erosion and sediment control measures.
- Based on the information provided and/or local weather conditions, the local permitting authority may expand or restrict the seasonal limitation on site disturbance.
- The following activities are exempt from the seasonal clearing and grading limitations:
  - Routine maintenance and necessary repair of erosion and sediment control BMPs;
  - Routine maintenance of public facilities or existing utility structures that do not expose the soil or result in the removal of the vegetative cover to soil; and
  - Activities where there is 100 percent infiltration of surface water runoff within the site in approved and installed erosion and sediment control facilities.

#### Coordination with Utilities and Other Jurisdictions

- Care has been taken to coordinate with utilities, other construction projects, and the local jurisdiction in preparing this SWPPP and scheduling the construction work.

#### Inspection and Monitoring

- All BMPs shall be inspected, maintained, and repaired as needed to assure continued performance of their intended function. Site inspections shall be conducted by a person who is knowledgeable in the principles and practices of erosion and sediment control. This person has the necessary skills to:
  - Assess the site conditions and construction activities that could impact the quality of stormwater, and

- Assess the effectiveness of erosion and sediment control measures used to control the quality of stormwater discharges.
- A Certified Erosion and Sediment Control Lead shall be on-site or on-call at all times.
- Whenever inspection and/or monitoring reveals that the BMPs identified in this SWPPP are inadequate, due to the actual discharge of or potential to discharge a significant amount of any pollutant, appropriate BMPs or design changes shall be implemented as soon as possible.

#### Maintaining an Updated Construction SWPPP

- This SWPPP shall be retained on-site or within reasonable access to the site.
- The SWPPP shall be modified whenever there is a change in the design, construction, operation, or maintenance at the construction site that has, or could have, a significant effect on the discharge of pollutants to waters of the state.
- The SWPPP shall be modified if, during inspections or investigations conducted by the owner/operator, or the applicable local or state regulatory authority, it is determined that the SWPPP is ineffective in eliminating or significantly minimizing pollutants in stormwater discharges from the site. The SWPPP shall be modified as necessary to include additional or modified BMPs designed to correct problems identified. Revisions to the SWPPP shall be completed within seven (7) days following the inspection.

### **3.2 Site Specific Construction BMPs**

Site specific BMPs are shown on the TESC Plan Sheets and Details in Appendix A. These site specific plan sheets will be updated annually.

### **3.3 Additional Advanced BMPs**

The following BMPs are advanced and will only be required if construction activities are complex enough to warrant them; or if the site has the potential for significant impacts to water quality. The following BMPs are directed at “end-of-pipe” treatment for sedimentation issues related to turbid runoff from construction sites. Effective BMPs are most often the simple BMPs, and focus on the minimization of erosion before sedimentation is an issue. The following BMPs will most likely be implemented only after other BMP options are exhausted, or if the construction activity is large and off-site sedimentation or turbid runoff occurs or is inevitable.

- For BMP 250, written pre-approval, through Ecology is required (see SWMMWW 2014):
- BMP C250: Construction Stormwater Chemical Treatment
- BMP C251: Construction Stormwater Filtration.



## 4.0 Construction Phasing and BMP Implementation

The BMP implementation schedule is driven by the construction schedule. The following provides a sequential list of the proposed construction schedule milestones and the corresponding BMP implementation schedule. The list contains key milestones such as wet season construction.

BMP implementation schedule listed below is keyed to proposed phases of the construction project, and reflects differences in BMP installations and inspections that relate to wet season construction. The project site is located west of the Cascade Mountain Crest. As such, the dry season is considered to be from May 1 to September 30 and the wet season is considered to be from October 1 to April 30.

- |   |                |
|---|----------------|
| ▪ Estimate of Construction start date:  | 06 / 01 / 2022 |
| ▪ Estimate of Construction finish date:   | 12 / 15 / 2023 |
| ▪ Mobilize equipment on site:   | 06 / 01 / 2022 |
| ▪ Mobilize and store all TESC and soil stabilization products (store materials on hand BMP C150): | 06 / 05 / 2022 |
| ▪ Install TESC measures:  | 06 / 08 / 2022 |
| ▪ Installation of soil nailing/site stabilization measures  | 06 / 15 / 2022 |
| ▪ Rough grading and installation of access driveway   | 07 / 15 / 2022 |
| ▪ Excavation and installation of storm drain facilities   | 08 / 01 / 2022 |
| ▪ Excavation and installation of addition foundations   | 08 / 01 / 2022 |
| ▪ Complete foundations and site utility construction  | 10 / 01 / 2022 |
| ▪ Complete mulch stabilization  | 07 / 15 / 2022 |
| ▪ Building Construction– Framing Complete   | 2 / 15 / 2023  |
| ▪ Site Paving Complete  | 09 / 01 / 2023 |
| ▪ Building– Interiors Complete  | 12 / 15 / 2023 |
| ▪ Soil Restoration – Final Plantings and site stabilization                                       | 10 / 15 / 2023 |
| ▪ Remove temporary erosion control measures:  | 11 / 15 / 2023 |

## 5.0 Pollution Prevention Team

### 5.1 Roles and Responsibilities

The pollution prevention team consists of personnel responsible for implementation of the SWPPP, including the following:

- Certified Erosion and Sediment Control Lead (CESCL) – primary contractor contact, responsible for site inspections (BMPs, visual monitoring, sampling, etc.); to be called upon in case of failure of any ESC measures.
- Resident Engineer – For projects with engineered structures only (sediment ponds/traps, sand filters, etc.): site representative for the owner that is the project's supervising engineer responsible for inspections and issuing instructions and drawings to the contractor's site supervisor or representative
- Emergency Ecology Contact – individual to be contacted at Ecology in case of emergency. [Go to the following website to get the name and number for the Ecology contact information: http://www.ecy.wa.gov/org.html.](http://www.ecy.wa.gov/org.html)
- Emergency Owner Contact – individual that is the site owner or representative of the site owner to be contacted in the case of an emergency.
- Non-Emergency Ecology Contact – individual that is the site owner or representative of the site owner than can be contacted if required.
- Monitoring Personnel – personnel responsible for conducting water quality monitoring; for most sites this person is also the Certified Erosion and Sediment Control Lead.

## 5.2 Team Members

Names and contact information for those identified as members of the pollution prevention team are provided in the following table.

Title	Name(s)	Phone Number
Certified Erosion and Sediment Control Lead (CESCL)	~TBD	~
Resident Engineer	~TBD	~
Emergency Ecology Contact (Spills)	~TBD	~
Water Quality (Ecology)	TBD	~
Emergency Owner Contact	~TBD	~
Non-Emergency Ecology Contact	~TBD	~
Monitoring Personnel	~TBD	~
Construction Observation - Owner	Dan and Susan Steinborn Tom Schultz and Jeff Wenzel, Mercer Builders	~
Construction Observation – Civil Engineer	John W. Rundall, P.E. WR Consulting, Inc.	206-850-1686 (cell) 206-285-1593 (office)

## 6.0 Site Inspections and Monitoring

Monitoring includes visual inspection, monitoring for water quality parameters of concern, and documentation of the inspection and monitoring findings in a site log book. A site log book will be maintained for all on-site construction activities and will include:

- A record of the implementation of the SWPPP and other permit requirements;
- Site inspections; and,
- Stormwater quality monitoring.

For convenience, the inspection form and water quality monitoring forms included in this SWPPP include the required information for the site log book. This SWPPP may function as the site log book if desired, or the forms may be separated and included in a separate site log book. However, if separated, the site log book but must be maintained on-site or within reasonable access to the site and be made available upon request to Ecology or the local jurisdiction.

### 6.1 Site Inspection

All BMPs will be inspected, maintained, and repaired as needed to assure continued performance of their intended function. Site inspections will be conducted by a person who is knowledgeable in the principles and practices of erosion and sediment control. The onsite inspector will have the skills to assess the potential for water quality impacts as a result of the type of construction activities occurring on site, and the knowledge of the appropriate and effective ESC measures needed to control the quality of stormwater discharges.

All BMPs will be inspected, maintained, and repaired as needed to assure continued performance of their intended function. The inspector will be a Certified Erosion and Sediment Control Lead (CESCL) per BMP C160. The name and contact information for the CESCL is provided in Section 5 of this SWPPP.

Site inspection will occur in all areas disturbed by construction activities and at all stormwater discharge points. Stormwater will be examined for the presence of suspended sediment, turbidity, discoloration, and oily sheen. The site inspector will evaluate and document the effectiveness of the installed BMPs and determine if it is necessary to repair or replace any of the BMPs to improve the quality of stormwater discharges. All maintenance and repairs will be documented in the site log book or forms provided in this document. All new BMPs or design changes will be documented in the SWPPP as soon as possible.

### **6.1.1 Site Inspection Frequency**

Site inspections will be conducted at least once a week and within 24 hours following any discharge from the site. For sites with temporary stabilization measures, the site inspection frequency can be reduced to once every month if the site is inactive.

### **6.1.2 Site Inspection Documentation**

The site inspector will record each site inspection using the site log inspection forms provided in Appendix D. The site inspection log forms may be separated from this SWPPP document, but will be maintained on-site or within reasonable access to the site and be made available upon request to Ecology or the local jurisdiction.

## **6.2 Stormwater Quality Monitoring**

The construction site is less than one acre in size, and does not discharge to an impaired water body, and is therefore not subject to the general water quality monitoring requirements set forth in the current Construction Stormwater General Permit .

### **6.2.1 Turbidity Sampling**

Monitoring requirements for the proposed project will include either turbidity or water transparency sampling to monitor site discharges for water quality compliance with the 2014 Construction Stormwater General Permit. Sampling will be conducted at all discharge points at least once per calendar week.

Turbidity or transparency monitoring will follow the analytical methodologies described in Section S4 of the current Construction Stormwater General Permit . The key benchmark values that require action are 25 NTU for turbidity (equivalent to 32 cm transparency) and 250 NTU for turbidity (equivalent to 6 cm transparency). If the 25 NTU benchmark for turbidity (equivalent to 32 cm transparency) is exceeded, the following steps will be conducted:

1. Ensure all BMPs specified in this SWPPP are installed and functioning as intended.
2. Assess whether additional BMPs should be implemented, and document revisions to the SWPPP as necessary.
3. Sample discharge location daily until the analysis results are less than 25 NTU (turbidity) or greater than 32 cm (transparency).

If the turbidity is greater than 25 NTU (or transparency is less than 32 cm) but less than 250 NTU (transparency greater than 6 cm) for more than 3 days, additional treatment BMPs will be implemented within 24 hours of the third consecutive sample that exceeded the benchmark value. Additional treatment BMPs to be considered will include, but are not limited to, off-site treatment, infiltration, filtration and chemical treatment.

If the 250 NTU benchmark for turbidity (or less than 6 cm transparency) is exceeded at any time, the following steps will be conducted:

1. Notify Ecology by phone within 24 hours of analysis (see Section 5.0 of this SWPPP for contact information).
2. Continue daily sampling until the turbidity is less than 25 NTU (or transparency is greater than 32 cm).
3. Initiate additional treatment BMPs such as off-site treatment, infiltration, filtration and chemical treatment within 24 hours of the first 250 NTU exceedance.
4. Implement additional treatment BMPs as soon as possible, but within 7 days of the first 250 NTU exceedance.
5. Describe inspection results and remedial actions taken in the site log book and in monthly discharge monitoring reports as described in Section 7.0 of this SWPPP.

### **6.2.2 pH Sampling and Monitoring**

Sampling and monitoring for pH will occur during the phase of construction when concrete pouring will be conducted until fully cured (3 weeks from last pour) and discharges are documented to be below pH 8.5. Samples will be collected weekly at the sedimentation pond prior to discharge to surface water. Samples will be analyzed for pH using a calibrated pH meter and recorded in the site log book.

The key benchmark pH value for stormwater is a maximum of 8.5. If a pH greater than 8.5 is measured in the sedimentation trap/pond(s) that has the potential to discharge to surface water, the following steps will be conducted:

1. Prevent (detain) all discharges from leaving the site and entering surface waters or storm drains if the pH is greater than 8.5
2. Implement CO<sub>2</sub> sparging or dry ice treatment in accordance with Ecology BMP C252.
3. Describe inspection results and remedial actions that are taken in the site log book and in monthly discharge monitoring reports as described in Section 7.0 of this SWPPP.

## 6.3 Stormwater Facilities Maintenance and Operation

This SWPPP also addresses the operation and maintenance of the proposed facility during construction. The long-term operation and maintenance is addressed in the Drainage Report, particularly the maintenance required for the detention facility. Removal of silt from the storage tanks is also important after construction is complete. The quantity of sediment from the roof and paved areas after construction is complete should be small relative to the size of the tanks.

The following outlines basic maintenance requirements for the conveyance and detention facilities on this project.

### 6.3.1 Conveyance System

Maintenance requirements for conveyance piping and catch basins are listed below:

**No. 21 - Conveyance Storm Pipes**

Drainage System Feature	Potential Defect	Conditions When Maintenance Is Needed	Results Expected When Maintenance Is Performed Or Not Needed
General	Obstructions, Including Roots	Root enters or deforms pipe, reducing flow.	Use mechanical methods to remove root if possible. Use of chemicals to remove roots shall be done in accordance with applicable regulations. If necessary, remove the vegetation over the line.
	Pipe Dented or Broken	Inlet/outlet piping damaged or broken and in need of repair.	Pipe repaired and/or replaced.
	Pipe Rusted or Deteriorated	Any part of the piping that is crushed or deformed more than 20% or any other failure to the piping.	Pipe repaired and/or replaced.
	Sediment & Debris	Sediment depth is greater than 20% of pipe diameter.	Install upstream debris traps (where applicable) then clean pipe and remove material.
	Debris barrier or Trash Rack Missing	A debris barrier or trash rack that had been installed on the end of a drainage pipe is missing	Debris barrier or trash rack is replaced.
	Joint/Seal Problems	The joint between pipe sections is separated and/or the seal at the joint is cracked or broken.	The joint and/or seal is repaired so that joint is not separated and is properly sealed.

**No. 5 – Catch Basins**

Maintenance Component	Defect	Conditions When Maintenance is Needed	Results Expected When Maintenance is performed
Ladder	Ladder Rungs Unsafe	Ladder is unsafe due to missing rungs, cracked/broken rungs, rungs not securely attached to basin wall, misalignment, rust, cracks, or sharp edges.	Ladder meets design standards and allows maintenance person safe access.
Metal Grates (If Applicable)	Trash and Debris	Trash and debris that is blocking more than 20% of grate surface inletting capacity.	Grate free of trash and debris.
	Damaged or Missing.	Grate missing or broken member(s) of the grate.	Grate is in place and meets design standards.

**6.3.2 Pumping Facility, Bioretention and Permeable Pavement**

Not applicable to this project.



## **7.0 Reporting and Recordkeeping**

### **7.1 Recordkeeping**

#### **7.1.1 Site Log Book**

A site log book will be maintained for all on-site construction activities and will include:

- A record of the implementation of the SWPPP and other permit requirements;
- Site inspections; and,
- Stormwater quality monitoring.

For convenience, the inspection form and water quality monitoring forms included in this SWPPP include the required information for the site log book.

#### **7.1.2 Records Retention**

Records of all monitoring information (site log book, inspection reports/checklists, etc.), this Stormwater Pollution Prevention Plan, and any other documentation of compliance with permit requirements will be retained during the life of the construction project and for a minimum of three years following the termination of permit coverage in accordance with permit condition S5.C.

#### **7.1.3 Access to Plans and Records**

The SWPPP, General Permit, Notice of Authorization letter, and Site Log Book will be retained on site or within reasonable access to the site and will be made immediately available upon request to Ecology or the local jurisdiction. A copy of this SWPPP will be provided to Ecology within 14 days of receipt of a written request for the SWPPP from Ecology. Any other information requested by Ecology will be submitted within a reasonable time. A copy of the SWPPP or access to the SWPPP will be provided to the public when requested in writing in accordance with permit condition S5.G.

#### **7.1.4 Updating the SWPPP**

In accordance with Conditions S3, S4.B, and S9.B.3 of the General Permit, this SWPPP will be modified if the SWPPP is ineffective in eliminating or significantly minimizing pollutants in stormwater discharges from the site or there has been a change in design, construction, operation, or maintenance at the site that has a significant effect on the discharge, or potential for discharge, of pollutants to the waters of the State. The SWPPP will be modified within seven days of determination based on inspection(s) that additional or modified BMPs are necessary to correct problems identified, and an updated timeline for BMP implementation will be prepared.

## **7.2 Reporting**

### **7.2.1 Discharge Monitoring Reports**

Water quality sampling results will be submitted to Ecology monthly on Discharge Monitoring Report (DMR) forms in accordance with permit condition S5.B. If there was no discharge during a given monitoring period, the form will be submitted with the words “no discharge” entered in place of the monitoring results. If a benchmark was exceeded, a brief summary of inspection results and remedial actions taken will be included. If sampling could not be performed during a monitoring period, a DMR will be submitted with an explanation of why sampling could not be performed.

### **7.2.2 Notification of Noncompliance**

If any of the terms and conditions of the permit are not met, and it causes a threat to human health or the environment, the following steps will be taken in accordance with permit section S5.F:

1. Ecology will be immediately notified of the failure to comply.
2. Immediate action will be taken to control the noncompliance issue and to correct the problem. If applicable, sampling and analysis of any noncompliance will be repeated immediately and the results submitted to Ecology within five (5) days of becoming aware of the violation.
3. A detailed written report describing the noncompliance will be submitted to Ecology within five (5) days, unless requested earlier by Ecology.

Any time turbidity sampling indicates turbidity is 250 nephelometric turbidity units (NTU) or greater or water transparency is 6 centimeters or less, the Ecology regional office will be notified by phone within 24 hours of analysis as required by permit condition S5.A (see Section 5.0 of this SWPPP for contact information).

In accordance with permit condition S4.F.6.b, the Ecology regional office will be notified if chemical treatment other than CO<sub>2</sub> sparging is planned for adjustment of high pH water (see Section 5.0 of this SWPPP for contact information).

### **7.2.3 Permit Application and Changes**

In accordance with permit condition S2.A, a complete application form will be submitted to Ecology and the appropriate local jurisdiction (if applicable) to be covered by the General Permit.

## **Appendix A – TESC PLAN and Details**



Vicinity Map

Site Coordinates: 47 deg 33' 39.40" N, 122 deg. 13' 13.27" W

## **Appendix B – Construction BMPs**

Source Control BMPs

- BMP C101: Preserving Natural Vegetation
- BMP C102: Buffer Zones
- BMP C103: High Visibility Fence
- BMP C105: Stabilized Construction Exit
- BMP C106: Wheel Wash
- BMP C107: Construction Road/Parking Area Stabilization
- BMP C120: Temporary and Permanent Seeding
- BMP C121: Mulching
- BMP C122: Blankets
- BMP C123: Plastic Covering
- BMP C124: Sodding
- BMP C125: Topsoiling / Composting
- BMP C126: Polyacrylamide (PAM) for Soil Erosion Protection
- BMP C130: Surface Roughening
- BMP C131: Gradient Terraces
- BMP C140: Dust Control
- BMP C150: Materials On Hand
- BMP C151: Concrete Handling
- BMP C152: Sawcutting and Surfacing Pollution Prevention
- BMP C153: Material Delivery, Storage and Containment
- BMP C154: Concrete Washout Facilities
- BMP C160: Certified Erosion and Sediment Control Lead
- BMP C162: Scheduling
- BMP C180: Small Project Construction Stormwater Pollution Prevention

Runoff Conveyance and Treatment BMPs

- BMP C200: Interceptor Dike and Swale
- BMP C201: Grass-Lined Channels
- BMP C202: Channel Lining
- BMP C203: Water Bars
- BMP C204: Pipe Slope Drains
- BMP C205: Subsurface Drains
- BMP C206: Level Spreader
- BMP C207: Check Dams
- BMP C208: Triangular Silt Dike
- BMP C209: Outlet Protection
- BMP C220: Storm Drain Inlet Protection
- BMP C231: Brush Barrier
- BMP C232: Gravel Filter Berm
- BMP C233: Silt Fence
- BMP C234: Vegetated Strip
- BMP C235: Wattles

BMP C236: Pumped Vegetative Dispersion (called Vegetative Filtration in the 2014 Ecology Stormwater Management Manual for Western Washington)

BMP C240: Sediment Trap

BMP C241: Temporary Sediment Pond

BMP C250: Construction Stormwater Chemical Treatment

BMP C251: Construction Stormwater Filtration

BMP C252: High pH Neutralization Using CO<sub>2</sub>

BMP C253: pH Control of High pH Stormwater

## **Appendix C – Alternative BMPs**

The following includes a list of possible alternative BMPs for each of the 12 elements not described in the main SWPPP text. This list can be referenced in the event a BMP for a specific element is not functioning as designed and an alternative BMP needs to be implemented.

### **Element #1 - Mark Clearing Limits**

- BMP C101: Preserving Natural Vegetation
- BMP C102: Buffer Zones
- BMP C103: High Visibility Plastic or Metal Fence
- BMP C104: Stake and Wire Fence

### **Element #2 - Establish Construction Access**

- BMP C105: Stabilized Construction Entrance
- BMP C106: Wheel Wash

### **Element #3 - Control Flow Rates**

- BMP C240: Sediment Trap
- BMP C241: Temporary Sediment Pond

### **Element #4 - Install Sediment Controls**

- BMP C230: Straw Bale Barrier
- BMP C231: Brush Barrier
- BMP C234: Vegetated Strip
- BMP C240: Sediment Trap
- BMP C241: Temporary Sediment Pond
- BMP C250: Construction Stormwater Chemical Treatment
- BMP C251: Construction Stormwater Filtration

### **Element #5 - Stabilize Soils**

- BMP C122: Nets and Blankets
- BMP C124: Sodding
- BMP C125: Topsoiling
- BMP C126: Polyacrylamide for Soil Erosion Protection
- BMP C131: Gradient Terrace

### **Element #6 - Protect Slopes**

- BMP C120: Temporary and Permanent Seeding
- BMP C130: Surface Roughening
- BMP C131: Gradient Terrace
- BMP C200: Interceptor Dike and Swale
- BMP C201: Grass-Lined Channels
- BMP C204: Pipe Slope Drains
- BMP C205: Subsurface Drains
- BMP C206: Level Spreader
- BMP C207: Check Dams
- BMP C208: Triangular Silt Dike (Geotextile-Encased Check Dam)

### **Element #8 - Stabilize Channels and Outlets**

- BMP C202: Channel Lining
- BMP C209: Outlet Protection



---

## Appendix D – Site Inspection Forms (and Site Log)

The results of each inspection shall be summarized in an inspection report or checklist that is entered into or attached to the site log book. It is suggested that the inspection report or checklist be included in this appendix to keep monitoring and inspection information in one document, but this is optional. However, it is mandatory that this SWPPP and the site inspection forms be kept onsite at all times during construction, and that inspections be performed and documented as outlined below.

At a minimum, each inspection report or checklist shall include:

- a. Inspection date/times
- b. Weather information: general conditions during inspection, approximate amount of precipitation since the last inspection, and approximate amount of precipitation within the last 24 hours.
- c. A summary or list of all BMPs that have been implemented, including observations of all erosion/sediment control structures or practices.
- d. The following shall be noted:
  - locations of BMPs inspected,
  - locations of BMPs that need maintenance,
  - the reason maintenance is needed,
  - locations of BMPs that failed to operate as designed or intended, and
  - locations where additional or different BMPs are needed, and the reason(s) why
- e. A description of stormwater discharged from the site. The presence of suspended sediment, turbid water, discoloration, and/or oil sheen shall be noted, as applicable.
- f. A description of any water quality monitoring performed during inspection, and the results of that monitoring.
- g. General comments and notes, including a brief description of any BMP or repairs, maintenance or installations made as a result of the inspection.
- h. A statement that, in the judgment of the person conducting the site inspection, the site is either in compliance or out of compliance with the terms and conditions of the SWPPP and the NPDES permit. If the site inspection indicates that the site is out of compliance, the inspection report shall include a summary of the

remedial actions required to bring the site back into compliance, as well as a schedule of implementation.

- i. Name, title, and signature of person conducting the site inspection; and the following statement: “I certify under penalty of law that this report is true, accurate, and complete, to the best of my knowledge and belief”.

When the site inspection indicates that the site is not in compliance with any terms and conditions of the NPDES permit, the Permittee shall take immediate action(s) to: stop, contain, and clean up the unauthorized discharges, or otherwise stop the noncompliance; correct the problem(s); implement appropriate Best Management Practices (BMPs), and/or conduct maintenance of existing BMPs; and achieve compliance with all applicable standards and permit conditions. In addition, if the noncompliance causes a threat to human health or the environment, the Permittee shall comply with the Noncompliance Notification requirements in Special Condition S5.F of the permit.

## Site Inspection Form

### General Information

**Project Name:** \_\_\_\_\_

**Inspector Name:** \_\_\_\_\_

**Title:** \_\_\_\_\_

**CESCL # :** \_\_\_\_\_

**Date:** \_\_\_\_\_

**Time:** \_\_\_\_\_

- Inspection Type:**
- After a rain event
  - Weekly
  - Turbidity/transparency benchmark exceedance
  - Other

**Weather** \_\_\_\_\_

**Precipitation** Since last inspection \_\_\_\_\_

In last 24 hours \_\_\_\_\_

**Description of General Site Conditions:** \_\_\_\_\_

### Inspection of BMPs

***Element 1: Mark Clearing Limits***

**BMP:** \_\_\_\_\_

Location	Inspected		Functioning			Problem/Corrective Action
	Y	N	Y	N	NIP	

**BMP:** \_\_\_\_\_

Location	Inspected		Functioning			Problem/Corrective Action
	Y	N	Y	N	NIP	

***Element 2: Establish Construction Access***

**BMP:** \_\_\_\_\_

Location	Inspected		Functioning			Problem/Corrective Action
	Y	N	Y	N	NIP	

**BMP:** \_\_\_\_\_

Location	Inspected		Functioning			Problem/Corrective Action
	Y	N	Y	N	NIP	

**Element 3: Control Flow Rates**

BMP:

Location	Inspected		Functioning			Problem/Corrective Action
	Y	N	Y	N	NIP	

BMP:

Location	Inspected		Functioning			Problem/Corrective Action
	Y	N	Y	N	NIP	

**Element 4: Install Sediment Controls**

BMP:

Location	Inspected		Functioning			Problem/Corrective Action
	Y	N	Y	N	NIP	

BMP:

Location	Inspected		Functioning			Problem/Corrective Action
	Y	N	Y	N	NIP	

BMP:

Location	Inspected		Functioning			Problem/Corrective Action
	Y	N	Y	N	NIP	

BMP:

Location	Inspected		Functioning			Problem/Corrective Action
	Y	N	Y	N	NIP	

BMP:

Location	Inspected		Functioning			Problem/Corrective Action
	Y	N	Y	N	NIP	

**Element 5: Stabilize Soils**

BMP:

Location	Inspected		Functioning			Problem/Corrective Action
	Y	N	Y	N	NIP	

BMP:

Location	Inspected		Functioning			Problem/Corrective Action
	Y	N	Y	N	NIP	

BMP:

Location	Inspected		Functioning			Problem/Corrective Action
	Y	N	Y	N	NIP	

BMP:

Location	Inspected		Functioning			Problem/Corrective Action
	Y	N	Y	N	NIP	

**Element 6: Protect Slopes**

BMP:

Location	Inspected		Functioning			Problem/Corrective Action
	Y	N	Y	N	NIP	

BMP:

Location	Inspected		Functioning			Problem/Corrective Action
	Y	N	Y	N	NIP	

BMP:

Location	Inspected		Functioning			Problem/Corrective Action
	Y	N	Y	N	NIP	

**Element 7: Protect Drain Inlets**

BMP:

Location	Inspected		Functioning			Problem/Corrective Action
	Y	N	Y	N	NIP	

BMP:

Location	Inspected		Functioning			Problem/Corrective Action
	Y	N	Y	N	NIP	

BMP:

Location	Inspected		Functioning			Problem/Corrective Action
	Y	N	Y	N	NIP	

**Element 8: Stabilize Channels and Outlets**

BMP:

Location	Inspected		Functioning			Problem/Corrective Action
	Y	N	Y	N	NIP	

BMP:

Location	Inspected		Functioning			Problem/Corrective Action
	Y	N	Y	N	NIP	

BMP:

Location	Inspected		Functioning			Problem/Corrective Action
	Y	N	Y	N	NIP	

BMP:

Location	Inspected		Functioning			Problem/Corrective Action
	Y	N	Y	N	NIP	

**Element 9: Control Pollutants**

BMP:

Location	Inspected		Functioning			Problem/Corrective Action
	Y	N	Y	N	NIP	

BMP:

Location	Inspected		Functioning			Problem/Corrective Action
	Y	N	Y	N	NIP	

**Element 10: Control Dewatering**

BMP:

Location	Inspected		Functioning			Problem/Corrective Action
	Y	N	Y	N	NIP	

BMP:

Location	Inspected		Functioning			Problem/Corrective Action
	Y	N	Y	N	NIP	

BMP:

Location	Inspected		Functioning			Problem/Corrective Action
	Y	N	Y	N	NIP	

Stormwater Discharges From the Site			
	Observed?		Problem/Corrective Action
	Y	N	
Location			
Turbidity	<input type="checkbox"/>	<input type="checkbox"/>	
Discoloration	<input type="checkbox"/>	<input type="checkbox"/>	
Sheen	<input type="checkbox"/>	<input type="checkbox"/>	
Location			
Turbidity	<input type="checkbox"/>	<input type="checkbox"/>	
Discoloration	<input type="checkbox"/>	<input type="checkbox"/>	
Sheen	<input type="checkbox"/>	<input type="checkbox"/>	



<b>Water Quality Monitoring</b>	
Was any water quality monitoring conducted? <input type="checkbox"/> Yes <input type="checkbox"/> No	
If water quality monitoring was conducted, record results here:	
If water quality monitoring indicated turbidity 250 NTU or greater; or transparency 6 cm or less, was Ecology notified by phone within 24 hrs?	
<input type="checkbox"/> Yes <input type="checkbox"/> No	
If Ecology was notified, indicate the date, time, contact name and phone number below:	
Date:	
Time:	
Contact Name:	
Phone #:	
<b>General Comments and Notes</b>	
Include BMP repairs, maintenance, or installations made as a result of the inspection.	
Were Photos Taken? <input type="checkbox"/> Yes <input type="checkbox"/> No	
If photos taken, describe photos below:	

## **Appendix E – Engineering Calculations**

Not Applicable

# Appendix D

## Operation and Maintenance

**Table V-4.5.2(3) Maintenance Standards - Closed Detention Systems (Tanks/Vaults)**

Maintenance Component	Defect	Conditions When Maintenance is Needed	Results Expected When Maintenance is Performed
Storage Area	Plugged Air Vents	One-half of the cross section of a vent is blocked at any point or the vent is damaged.	Vents open and functioning.
	Debris and Sediment	Accumulated sediment depth exceeds 10% of the diameter of the storage area for 1/2 length of storage vault or any point depth exceeds 15% of diameter. (Example: 72-inch storage tank would require cleaning when sediment reaches depth of 7 inches for more than 1/2 length of tank.)	All sediment and debris removed from storage area.
	Joints Between Tank/Pipe Section	Any openings or voids allowing material to be transported into facility. (Will require engineering analysis to determine structural stability).	All joint between tank/pipe sections are sealed.
	Tank Pipe Bent Out of Shape	Any part of tank/pipe is bent out of shape more than 10% of its design shape. (Review required by engineer to determine structural stability).	Tank/pipe repaired or replaced to design.
	Vault Structure Includes Cracks in Wall, Bottom, Damage to Frame and/or Top Slab	Cracks wider than 1/2-inch and any evidence of soil particles entering the structure through the cracks, or maintenance/inspection personnel determines that the vault is not structurally sound.  Cracks wider than 1/2-inch at the joint of any inlet/outlet pipe or any evidence of soil particles entering the vault through the walls.	Vault replaced or repaired to design specifications and is structurally sound.  No cracks more than 1/4-inch wide at the joint of the inlet/outlet pipe.
Manhole	Cover Not in Place	Cover is missing or only partially in place. Any open manhole requires maintenance.	Manhole is closed.

**Table V-4.5.2(3) Maintenance Standards - Closed Detention Systems  
(Tanks/Vaults) (continued)**

Maintenance Component	Defect	Conditions When Maintenance is Needed	Results Expected When Maintenance is Performed
	Locking Mechanism Not Working	Mechanism cannot be opened by one maintenance person with proper tools. Bolts into frame have less than 1/2 inch of thread (may not apply to self-locking lids).	Mechanism opens with proper tools.
	Cover Difficult to Remove	One maintenance person cannot remove lid after applying normal lifting pressure. Intent is to keep cover from sealing off access to maintenance.	Cover can be removed and reinstalled by one maintenance person.
	Ladder Rungs Unsafe	Ladder is unsafe due to missing rungs, misalignment, not securely attached to structure wall, rust, or cracks.	Ladder meets design standards. Allows maintenance person safe access.
Catch Basins	See "Catch Basins" (No. 5)	See "Catch Basins" (No. 5).	See "Catch Basins" (No. 5).

**Table V-4.5.2(4) Maintenance Standards - Control Structure/Flow Restrictor**

Maintenance Component	Defect	Condition When Maintenance is Needed	Results Expected When Maintenance is Performed
General	Trash and Debris (Includes Sediment)	Material exceeds 25% of sump depth or 1 foot below orifice plate.	Control structure orifice is not blocked. All trash and debris removed.
	Structural Damage	Structure is not securely attached to manhole wall. Structure is not in upright position (allow up to 10% from plumb). Connections to outlet pipe	Structure securely attached to wall and outlet pipe. Structure in correct position. Connections to outlet pipe are water tight; structure repaired or replaced and works as

**Table V-4.5.2(4) Maintenance Standards - Control Structure/Flow Restrictor (continued)**

Maintenance Component	Defect	Condition When Maintenance is Needed	Results Expected When Maintenance is Performed
		are not watertight and show signs of rust. Any holes - other than designed holes - in the structure.	designed. Structure has no holes other than designed holes.
Cleanout Gate	Damaged or Missing	Cleanout gate is not watertight or is missing. Gate cannot be moved up and down by one maintenance person. Chain/rod leading to gate is missing or damaged. Gate is rusted over 50% of its surface area.	Gate is watertight and works as designed. Gate moves up and down easily and is watertight. Chain is in place and works as designed. Gate is repaired or replaced to meet design standards.
Orifice Plate	Damaged or Missing	Control device is not working properly due to missing, out of place, or bent orifice plate.	Plate is in place and works as designed.
	Obstructions	Any trash, debris, sediment, or vegetation blocking the plate.	Plate is free of all obstructions and works as designed.
Overflow Pipe	Obstructions	Any trash or debris blocking (or having the potential of blocking) the overflow pipe.	Pipe is free of all obstructions and works as designed.
Manhole	See "Closed Detention Systems" (No. 3).	See "Closed Detention Systems" (No. 3).	See "Closed Detention Systems" (No. 3).
Catch Basin	See "Catch Basins" (No. 5).	See "Catch Basins" (No. 5).	See "Catch Basins" (No. 5).

**Table V-4.5.2(5) Maintenance Standards - Catch Basins**

Maintenance Component	Defect	Conditions When Maintenance is Needed	Results Expected When Maintenance is performed
General	Trash & Debris	<p>Trash or debris which is located immediately in front of the catch basin opening or is blocking inletting capacity of the basin by more than 10%.</p> <p>Trash or debris (in the basin) that exceeds 60 percent of the sump depth as measured from the bottom of basin to invert of the lowest pipe into or out of the basin, but in no case less than a minimum of six inches clearance from the debris surface to the invert of the lowest pipe.</p> <p>Trash or debris in any inlet or outlet pipe blocking more than 1/3 of its height.</p> <p>Dead animals or vegetation that could generate odors that could cause complaints or dangerous gases (e.g., methane).</p>	<p>No Trash or debris located immediately in front of catch basin or on grate opening.</p> <p>No trash or debris in the catch basin.</p> <p>Inlet and outlet pipes free of trash or debris.</p> <p>No dead animals or vegetation present within the catch basin.</p>
	Sediment	<p>Sediment (in the basin) that exceeds 60 percent of the sump depth as measured from the bottom of basin to invert of the lowest pipe into or out of the basin, but in no case less than a minimum of 6 inches clearance from the sediment surface to the invert of the lowest pipe.</p>	<p>No sediment in the catch basin</p>
	Structure Damage to Frame and/or Top Slab	<p>Top slab has holes larger than 2 square inches or cracks wider than 1/4 inch. (Intent is to make sure no material is running into basin).</p>	<p>Top slab is free of holes and cracks.</p> <p>Frame is sit-</p>

**Table V-4.5.2(5) Maintenance Standards - Catch Basins (continued)**

Maintenance Component	Defect	Conditions When Maintenance is Needed	Results Expected When Maintenance is performed
		Frame not sitting flush on top slab, i.e., separation of more than 3/4 inch of the frame from the top slab. Frame not securely attached	ting flush on the riser rings or top slab and firmly attached.
	Fractures or Cracks in Basin Walls/ Bottom	Maintenance person judges that structure is unsound. Grout fillet has separated or cracked wider than 1/2 inch and longer than 1 foot at the joint of any inlet/outlet pipe or any evidence of soil particles entering catch basin through cracks.	Basin replaced or repaired to design standards. Pipe is regouted and secure at basin wall.
	Settlement/ Misalignment	If failure of basin has created a safety, function, or design problem.	Basin replaced or repaired to design standards.
	Vegetation	Vegetation growing across and blocking more than 10% of the basin opening. Vegetation growing in inlet/outlet pipe joints that is more than six inches tall and less than six inches apart.	No vegetation blocking opening to basin. No vegetation or root growth present.
	Contamination and Pollution	See "Detention Ponds" (No. 1).	No pollution present.
Catch Basin Cover	Cover Not in Place	Cover is missing or only partially in place. Any open catch basin requires maintenance.	Catch basin cover is closed
	Locking Mechanism Not	Mechanism cannot be opened by one maintenance person with proper tools. Bolts into	Mechanism opens with



**Table V-4.5.2(5) Maintenance Standards - Catch Basins (continued)**

Maintenance Component	Defect	Conditions When Maintenance is Needed	Results Expected When Maintenance is performed
	Working	frame have less than 1/2 inch of thread.	proper tools.
	Cover Difficult to Remove	One maintenance person cannot remove lid after applying normal lifting pressure. (Intent is keep cover from sealing off access to maintenance.)	Cover can be removed by one maintenance person.
Ladder	Ladder Rungs Unsafe	Ladder is unsafe due to missing rungs, not securely attached to basin wall, misalignment, rust, cracks, or sharp edges.	Ladder meets design standards and allows maintenance person safe access.
Metal Grates (If Applicable)	Grate opening Unsafe	Grate with opening wider than 7/8 inch.	Grate opening meets design standards.
	Trash and Debris	Trash and debris that is blocking more than 20% of grate surface inletting capacity.	Grate free of trash and debris.
	Damaged or Missing.	Grate missing or broken member(s) of the grate.	Grate is in place and meets design standards.

### No. 21 - Conveyance Storm Pipes

Drainage System Feature	Potential Defect	Conditions When Maintenance Is Needed	Results Expected When Maintenance Is Performed Or Not Needed
General	Obstructions, Including Roots	Root enters or deforms pipe, reducing flow.	Use mechanical methods to remove root if possible. Use of chemicals to remove roots shall be done in accordance with applicable regulations. If necessary, remove the vegetation over the line.
	Pipe Dented or Broken	Inlet/outlet piping damaged or broken and in need of repair.	Pipe repaired and/or replaced.
	Pipe Rusted or Deteriorated	Any part of the piping that is crushed or deformed more than 20% or any other failure to the piping.	Pipe repaired and/or replaced.
	Sediment & Debris	Sediment depth is greater than 20% of pipe diameter.	Install upstream debris traps (where applicable) then clean pipe and remove material.
	Debris barrier or Trash Rack Missing	A debris barrier or trash rack that had been installed on the end of a drainage pipe is missing	Debris barrier or trash rack is replaced.
	Joint/Seal Problems	The joint between pipe sections is separated and/or the seal at the joint is cracked or broken.	The joint and/or seal is repaired so that joint is not separated and is properly sealed.